



## **Metropolitan Sewer District of Greater Cincinnati**

# **Enabled Impact Program: Interim Summary Report – November 2013**



## 1. Introduction

The Metropolitan Sewer District (MSD) is among the top 5 Combined Sewer Overflow (CSO) dischargers in the country, discharging approximately 11 billion gallons of overflow during a typical year of rainfall. MSD is implementing an integrated, watershed based approach to reducing CSO volume. This approach, titled Project Groundwork, is an effort to improve the quality of our lives — through cleaner streams, improved protection of public health, and enhancements to the communities where we work, live, and play. The program is designed to assess whether sustainable stormwater infrastructure, either alone or integrated with more traditional stormwater management approaches, can have a meaningful impact on the reduction of CSOs in the MSD service area, particularly in the Lower Mill Creek. The program is comprised of individual projects which range widely in size, scope, complexity, location, and surrounding land use. These projects are categorized into two primary categories: Direct Impact and Enabled Impact Projects.

As a lead role in the watershed based approach, Direct Impact Projects provide source control through strategic separation, detention, stream separation and other sustainable infrastructure techniques. Direct Impact Projects are projects and assets that MSD owns and operates to reduce flow entering the system through strategic separation of stormwater and natural drainage.

Enabled Impact Projects rely on partnerships with public and private entities to implement source control solutions to reduce stormwater from entering the combined sewer system (CSS). Through these partnerships, Enabled Impact Projects provide additional value and benefits which lead to greater understanding of sustainable infrastructure. This greater understanding can be leveraged and shared within local service area communities. Early in MSD's implementation of Project Groundwork, the Enabled Impact Program was subdivided into two parts: the Green Demonstration Program and Early Success Projects. Through evolution, and in an effort to build on the base of projects constructed, MSD now implements Enabled Impact Projects under the program title only.

This report includes project status updates for the 2013 Board approved projects, an EIP project summary, updated monitoring status, project summaries, and maintenance summary sheets.

## 2. 2013 Board Approved Projects – Status Update

In the spring of 2013, MSD submitted a formal request to the Board of County Commissioners (Board) recommending the advancement of three (3) enabled impact projects under the Sustainable Infrastructure Allowance 10180900. All three projects were approved by the Board and are currently in varying phases of design and/or construction. See below for project status updates:

- Roselawn Park Early Success Project – Design complete, contract awarded Fall 2013, construction to start December 2013
- Urban Water Grant – North Fairmount (Carll/Denham Ravine) – Currently in the design phase, this project is expected to be legislated for construction in the second quarter of 2014
- West Fork Creek Riparian/Floodplain Restoration Project – Currently in final design, this project is planned to start construction in the second quarter of 2014

Each of these projects is located within the Lower Mill Creek watershed and could provide additional certainty and CSO reduction. MSD selected these projects based on their applicability to a future MSD source control project, project readiness, and alternative funding commitments.

### **3. 2013 Projects Receiving MSD Grant Match Funds**

In June 2012, Mill Creek Watershed Council of Communities (MCWCC) sponsored the submission of a Section 319(h) Nonpoint Source Program grant application to Ohio EPA for \$198,886 with a local match of \$158,947 for installation of green infrastructure at the project site. In March 2013, the grant was awarded to this project and the Board approved design and construction match funds in July. Partnering with Cincinnati Public Schools and MCWCC, the Roberts Academy Stormwater Control Project will implement a full-scale retrofit to the existing stormwater detention basin located on the school campus along Grand Avenue. The project will provide approximately 1.25 MG of stormwater removal in a typical year storm event. Currently in the early design stages, the Roberts Academy Stormwater Control Project is expected to begin construction late summer, early fall of 2014.

### **4. Enabled Impact Program Summary**

In 2010, MSD began an enabled impact program (EIP) throughout priority watersheds within the Lower Mill Creek. These projects are site-specific stormwater management strategies that may provide both water quantity and quality benefits, and which built support and trust within the community and watershed stakeholders. The EIP projects implement best management practices such as bioinfiltration features, reforestation, and porous pavement systems. Long term maintenance of the green infrastructure controls becomes the responsibility of the property owner.

In 2011, MSD began developing strategies to support a comprehensive monitoring program aimed at collecting combined sewer and sustainable stormwater infrastructure performance (flow) data, confirming effectiveness of the stormwater sewer separation projects, and synthesize this data for application on future Direct and Enabled Impact Projects.

In 2012, following the successful implementation of over 30 EIP projects, MSD refocused its efforts to capitalize on the strengths of its experience (e.g. effective best management practices, public outreach and education,) and encouraged MSD partners to identify additional funding mechanisms to implement the projects beyond sole sponsorship by MSD. As the Enabled Impact Program moves forward, MSD will continue to identify project opportunities, explore alternative funding sources (e.g. grants, project partnering, and community organizations.)

The enabled impact program has matured beyond demonstration and follows Board direction provided to MSD. Previously, demonstration and early success projects were funded using CIP Planning funds and nearly 40 projects have been developed with project partners between 2009 and 2012. In 2013 and moving forward, the Enabled Impact Program shall only utilize capital funds if a project improves an existing County/MSDGC asset, or if it creates a new County/MSD asset. Ownership of the asset is a critical criterion for capitalization decisions. If MSD operates and/or has maintenance responsibility then it will be considered and recorded as an MSD asset.

Enabled impact projects are also referenced in the LMCPR Study Report and classified as *Other Lower Mill Creek Projects* to assist in achieving watershed objectives. The report provided a brief summary of the enabled impact projects whether in design phase, construction phase, or previously installed – 86 MG of stormwater reduction annually for all projects within the combined system, system wide. Of the 86 MG, 64 MG of stormwater reduction is within the Lower Mill Creek watershed, 35 MG of stormwater reduction has already been installed (in the Lower Mill Creek watershed) – these projects help to provide greater certainty in meeting the volumetric targets of the LMCPR. The enabled impact projects are one part of the overall sustainable solution that includes source control, conveyance, storage and treatment.

MSD has utilized direct impact, enabled impact and inform & influence projects for integrated source control solutions throughout the MSD service area including as part of the Lower Mill Creek Partial Remedy (LMCPR). These three types of projects have developed over the past three years through Sustainable Watershed Evaluation Planning Process (SWEPP) evaluations and programmatic considerations along with policy direction provided by the Board. Table 1 below details all projects included in the enabled impact program. The identified projects within the Revised Original LMCPR are direct MSD-constructed, operated and managed projects. Direct source control projects are planned and designed to achieve CSO reduction goals, but they may also address other community priorities, such as water quality, flooding and/or public health. These issues are taken into account to develop projects within the context of the existing community and watershed conditions.

The Cincinnati Park Board (CPB) and MSD continue to collaborate through a Memorandum of Understanding (MOU) intended to allow CPB to assist MSD in the implementation of a Sustainable Infrastructure Program. The MOU builds upon CPB's experience in mitigating stormwater runoff through urban forest development, reforestation, and implementation of green infrastructure. The MOU also creates a mechanism for CPB to assist MSD with maintenance, project development, and public relations support for green infrastructure and canopy development in priority watersheds. In 2013, Parks' contribution to the enabled impact program consisted of pre-construction coordination, construction inspection and oversight, maintenance of established stormwater controls, continuing reforestation efforts, community outreach through volunteer events, and seeking out grant opportunities for MSD projects. A full report of CPB's work under the MOU for the year 2013 will be available following the first quarter of 2014.

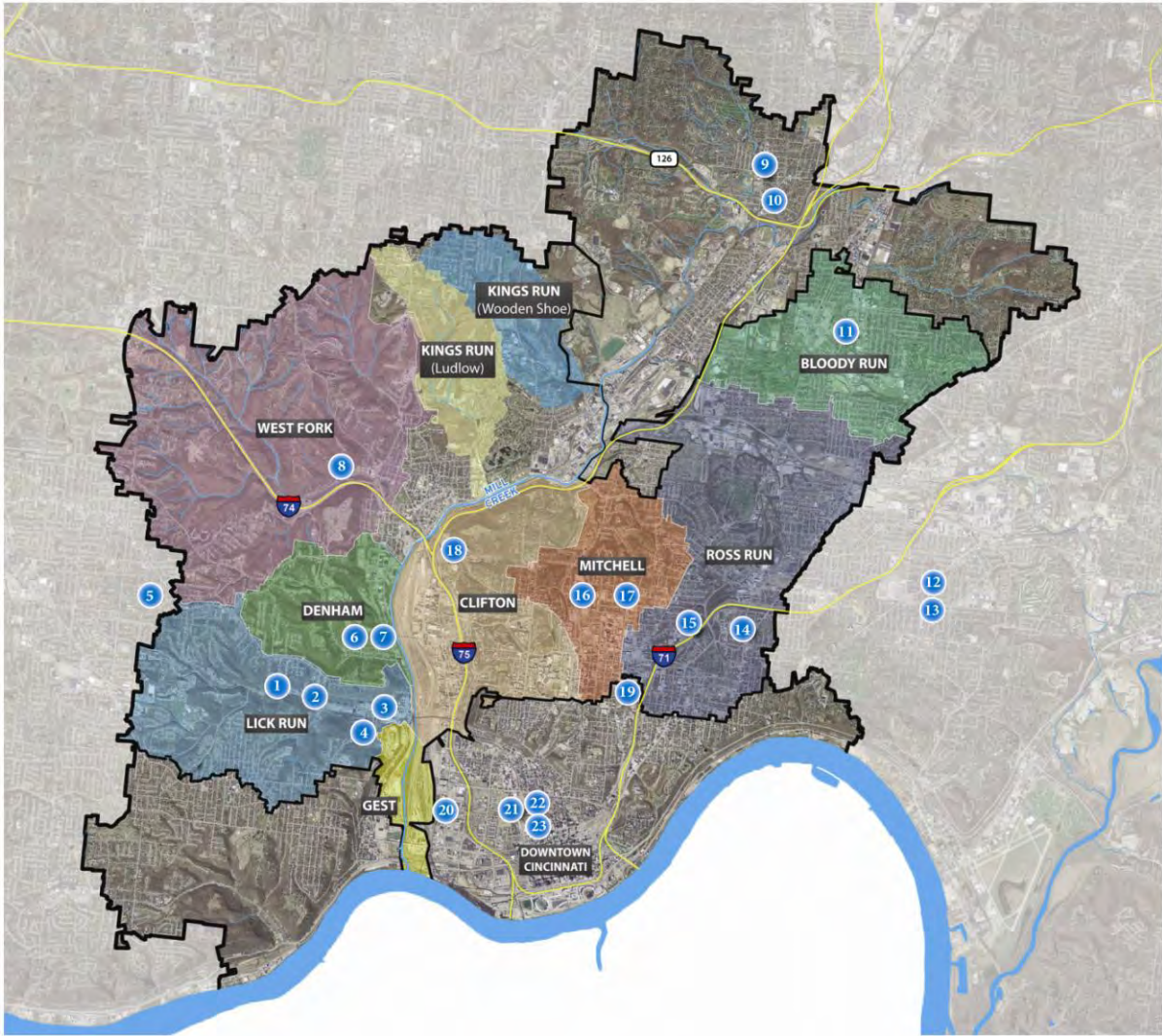

Figure 1: Map Index for Enabled Impact Projects within the Lower Mill Creek Basin

**Table 1:** Enabled Impact Projects Summary

<i>Project Partner</i>	<i>Map Index</i>	<i>Project Name</i>	<i>Green Infrastructure Type</i>	<i>Project Status</i>	<i>Estimated Annual Stormwater Capture Volume (gal)</i>	<i>Status Summary</i>
American Red Cross	15	Red Cross Building	Green Roof: Extensive Sloped	I	978,000	Construction is complete. Quarterly site inspections are assessing control performance and maintenance.
			Bioinfiltration Trench			
			Bioswale			
Archbishop of Cincinnati	1	San Antonio Church ESP	Pervious Pavement: Pavers	I	470,000	Construction completed in early 2012. Annual site inspections are assessing control performance and maintenance.
			Bioinfiltration Area			
Christ Hospital	24	Christ Hospital Bioswales	Bioinfiltration Basin	R	243,000	Original construction completed in 2010. Due to Christ development and expansion, the basins had to be removed. Per the funding agreement, Christ is required to reinstall the basins equal to 4 times the original asset.
Cincinnati DOTE	22	Comer Alley	Pervious Pavement: Pavers	I	150,000	Construction is complete. Annual site inspections are assessing control performance and maintenance.
	n/a	Harrison Avenue ESP	Bioinfiltration Area/Street Planter	UC	24,300	Construction is scheduled for completion late Fall 2013.
	12	Oakley Square	Pervious Pavement: Concrete	I	220,000	Construction is complete. Annual site inspections are assessing control performance and maintenance.
			Rain Garden: Urban Planter			
			Rain Garden: Natural			
22	Osborn Alley	Pervious Pavement: Pavers	I	228,000	Construction completed in summer 2011. Annual site inspections are assessing control performance and maintenance.	
Cincinnati Museum Center	20	Museum Center Green Roof	Green Roof: Extensive (shallow)	I	95,000	Construction is complete. Quarterly site inspections are assessing control performance and maintenance.
Cincinnati Parks	19	Washington Park	Dry Wells	I	3,864,000	Construction is complete. Annual site inspections are assessing control performance and maintenance.
			Green Roof: Extensive (shallow)			
	n/a	Queen City Avenue Reforestation	Reforestation	On	TBD	Parks continues to plan and implement additional reforestation efforts utilizing volunteers when possible.
11	Roselawn Park	Bioinfiltration Area	UC	526,000	Design complete, contract awarded Fall 2013, construction to start December 2013.	
		Reforestation				

<i>Project Partner</i>	<i>Map Index</i>	<i>Project Name</i>	<i>Green Infrastructure Type</i>	<i>Project Status</i>	<i>Estimated Annual Stormwater Capture Volume (gal)</i>	<i>Status Summary</i>	
Cincinnati Public Schools	13	CPS Clark Montessori	Rain Garden: Urban Planter	I	1,875,000	Construction is complete. Quarterly site inspections are assessing control performance and maintenance.	
			Green Roof: Intensive & Extensive				
			Bioswale				
			Pervious Pavement: Pavers				
			Pervious Pavement: Concrete				
	10	CPS Hartwell	Pervious Pavement: Concrete	I	614,000		Construction is complete. Annual site inspections are assessing control performance and maintenance.
	17	CPS North Avondale	Green Roof: Modular	I	10,000		Construction is complete. Annual site inspections are assessing control performance and maintenance.
21	CPS Taft IT	Bioinfiltration Basin	I	610,000	Construction is complete. Annual site inspections are assessing control performance and maintenance.		
		Green Roof: Modular Extensive					
Cincinnati Recreation Commission	6	North Fairmount Sprayground	Pervious Pavement: Concrete	I	100,000	Construction is complete.	
	14	Evanston Aquatic Center	Pervious Pavement: Concrete	I	1,730,000	Construction is complete. Quarterly site inspections are assessing control performance and maintenance.	
Bioinfiltration Basin							
Cincinnati State Technical College	18	Phase 2	Bioswale	I	8,000,000	Construction is complete. Quarterly site inspections are assessing control performance and maintenance.	
			Level Spreader				
			Rainwater Harvesting: Cistern				
			Bioinfiltration Basins				
			Rainwater Harvesting & Reuse				
			Pervious Pavement: Pavers				
			Bioinfiltration Trench				
		Phase 1	Rain Garden: Natural		4,620,000		
			Bioswale				
			Pervious Pavement: Concrete				
			Pervious Pavement: Pavers				
			Bioswale				
			Pervious Pavement: Asphalt				



<i>Project Partner</i>	<i>Map Index</i>	<i>Project Name</i>	<i>Green Infrastructure Type</i>	<i>Project Status</i>	<i>Estimated Annual Stormwater Capture Volume (gal)</i>	<i>Status Summary</i>
Cincinnati Zoo	16	African Savannah Phase 1	Rainwater Harvesting & Reuse	I	12,320,000	Construction is complete.
			Storm Sewer Separation			
		African Savannah Phase 2	Pervious Pavement: Pavers	I	3,100,000	Construction is complete.
			Enhanced Turf System			
			Tree Wells			
		Zoo Main Entry	Pervious Pavement: Pavers	I	1,107,000	Construction is complete. Quarterly site inspections are assessing control performance and maintenance.
Rainwater Harvesting: Cistern						
Civic Garden Center	19	Green Learning Station	Rainwater Harvesting: Cistern	I	40,000	Construction is complete. Quarterly site inspections are assessing control performance and maintenance.
			Pervious Pavement: Asphalt			
			Bioswale			
			Pervious Pavement: Concrete			
			Pervious Pavement: Pavers			
Groundwork Cincinnati Mill Creek	8	West Fork Creek Riparian/Floodplain Restoration Project	Bioinfiltration Area	D	510,000	Currently in final design, this project is planned to start construction in the second quarter of 2014.
			Vegetated Swales			
Immanuel Christ Church	3	Immanuel Christ Church ESP	Bioinfiltration Area	I	10,000	Construction is complete. Annual site inspections are assessing control performance and maintenance.
Mill Creek Watershed Council of Communities	7	Urban Water Grant - North Fairmount (Carll/Denham Ravine)	Bioswale	D	250,000	Currently in the design phase, this project is expected to be legislated for construction in the second quarter of 2014.
MSD and City of Wyoming	n/a	Pilot Rain Barrel Program	Rainwater Harvesting: Barrels	F	45,000	Project is complete.
Rain Garden Alliance	18	RGA Rain Garden	Rain Garden: Natural	I	140,000	Construction is complete. Quarterly site inspections are assessing control performance and maintenance.

<i>Project Partner</i>	<i>Map Index</i>	<i>Project Name</i>	<i>Green Infrastructure Type</i>	<i>Project Status</i>	<i>Estimated Annual Stormwater Capture Volume (gal)</i>	<i>Status Summary</i>
St. Francis Court Apartments	2	St. Francis Court Apartments Phase I	Bioinfiltration Area	I	723,100	Construction is complete. MSD has a Conservation Easement of the basins which requires St. Francis to pay for maintenance and upkeep (performed by CPB).
Westwood CURC	5	Former Habig's Parking Lot	Pervious Pavement: Pavers	I	380,000	Construction is complete. Annual site inspections are assessing control performance and maintenance. Westwood CURC was granted money to repave and seal the existing parking lot.
			Bioinfiltration Area			
Wyoming Board of Education	9	Wyoming High School	Bioinfiltration Basin Retrofit	I	100,000	Construction is complete. Annual site inspections are assessing control performance and maintenance.

D = Design Phase; UC = Under Construction; I = Installed; F = Finished; On = Ongoing; R = Removed

\*Project located outside of the Lower Mill Creek watershed boundary

## 5. Projects Monitoring Program

MSD recognized that the assessment of sustainable stormwater infrastructure performance was critical in order to evaluate the efficiency of the constructed systems and identify methods of improving the planning, design, and construction of green infrastructure systems. MSD developed a comprehensive monitoring approach which encompasses a variety of objectives including the identification of design lessons-learned, constructability constraints, stormwater runoff volume reduction, vegetative success, operational/functional issues, maintenance needs, and long-term viability. These objectives lend themselves to both quantitative and qualitative monitoring approaches, depending on the nature of a specific project. Currently MSD has implemented preconstruction quantitative flow monitoring on select projects (typically larger scale, more complex projects) to establish a baseline of preexisting stormwater flow rates within the combined sewer system. In 2011, with the assistance of Dr. Robert Pitt of the University Of Alabama (UA), MSD began developing strategies to incorporate quantitative monitoring provisions into selected Enabled Impact Projects during the design phase. Dr. Pitt made design modification recommendations during the design of three projects, with the overall goal of meeting MSD's previously mentioned objectives. These recommendations were incorporated into the monitoring plan of the Cincinnati State project, and have been incorporated into the construction documents for the Cat Canyon and University of Cincinnati projects. (The construction of the Cat Canyon and University of Cincinnati projects is on hold.)

The monitoring plan for Cincinnati State Technical Community College (CSTCC) was updated in 2012 by the United States Environmental Protection Agency (US EPA) and United States Geological Survey (USGS) to accommodate the availability of equipment at US EPA and can be utilized on this project. In November 2013, the monitoring equipment is going to be installed at the Cincinnati State site and initial analysis is expected in Q2 2014.

To ensure that overall long-term performance will be assessed at all locations, each completed project will be subjected to qualitative monitoring efforts. This will include seasonal and wet weather site inspections to assess the conditions of the controls and to identify any operation and maintenance issues. Table 2 below illustrates the qualitative and quantitative monitoring effort for each implemented Enabled Impact Project.

Following the table is a detailed discussion for projects that are being monitored. The data for these projects is currently being analyzed to inform MSD about the efficiency and effectiveness of the implemented systems. The discussion highlights the Green Learning Center, Cincinnati Museum Center, Washington Park, Cincinnati Zoo, Cincinnati State, and Clark Montessori School.

**Table 2:** Qualitative and Quantitative Monitoring of EI Projects

Project	Quantitative		Qualitative (post-con)	Monitoring Partners (in addition to MSD)	Comment
	Pre-con	Post-con			
Red Cross Building			YES	Cincinnati Park Board (CPB)	
Christ Hospital Bioswales			YES	CPB	Christ Hospital, as part of its expansion, has demolished the existing bioswales and plans to build back four times the original area in replacement bioswales.
Comer Alley			YES	CPB	
Oakley Square			YES		
Osborn Alley			YES		
Museum Center Green Roof		YES	YES	Urban Alta, CPB	Urbanalta and CDMSmith to provide the data and analysis prior to presenting at EWRI and Ohio Stormwater conferences.
Washington Park	YES	YES	YES	CPB	Currently MSD is working with Parks to retrieve the transducers and conduct the data analytical methods.
CPS Clark Montessori	YES	YES	YES	US EPA, CPB, UA	US EPA is currently monitoring the green infrastructure elements and has not conducted numerical analysis yet.
CPS Hartwell			YES	CPB	
CPS North Avondale			YES	CPB	
CPS Taft IT			YES	CPB	
Evanston Aquatic Center			YES	CPB	
Cincinnati State	YES	YES	YES	US EPA, USGS, CPB, Cincinnati State, UA	US EPA and USGS to implement the quantitative monitoring plan for the site. To be installed in November 2013.
African Savannah	YES	YES	YES	USGS, CPB	
Zoo Main Entry	YES	YES	YES	USGS, CPB, UA	An updated monitoring plan for the zoo entry area is being implemented with assistance from USGS.
Green Learning Station		YES	YES	Civic Garden Center, Urban Alta, CPB	
Pilot Rain Barrel				CPB	

Project	Quantitative		Qualitative (post-con)	Monitoring Partners (in addition to MSD)	Comment
	Pre-con	Post-con			
RGA Rain Garden			YES	CPB	
Wyoming High School			YES	CPB	
Former Habig's Parking			YES	CPB	
Immanuel Church			YES	CPB	
San Antonio Church			YES	CPB	
St. Francis Court	YES	YES	YES	US EPA, USGS	
Cincinnati Public Schools – Oyler School			YES	CPB	
Mercer Commons			YES	CPB	

**Green Learning Center at Cincinnati Civic Garden Center**

***Green Roof***

The monitoring at this site is being conducted by University of Cincinnati (UC) and Urbanalta. Urbanalta is a Hi-Tech startup company that utilizes the image sensory technology to measure flow and calculate runoff. UC is testing the performance of the green roof. The stormwater runoff from this roof is being evaluated for both the water quality and quantity. This roof is divided into 2 halves. One half is planted with local vegetation and the 2<sup>nd</sup> half is not vegetated (traditional). The following exhibit shows the setup for this roof.



Conventional and green roof at the green learning center

The conducted analyses on the roof were from the following studies:

1. Monitoring of runoff water quality from a 50m<sup>2</sup> sloped extensive green roof from all rain events for 18 months, together with a shingled “traditional roof” control and incoming precipitation water quality.
2. Runoff water quality from 24 small (1ft x 2ft) plot-scale green roof microcosms from 4 rain events during Aug-Sept 2011. Treatments including varying plant types.
3. Leachate water quality from common green roof growth medium components used in the plot-scale experiments including: sand, heat expanded shale, heat expanded clay, mushroom compost, and Canadian peat.

The following exhibit presents the setup and the analysis for the green roof at the green learning center.

# Green Roof Ecosystem Services and Disservices: Nutrient and Metal Cycling

Ishi Buffam<sup>1</sup> and Richard D. Durtsche<sup>2</sup>

<sup>1</sup>University of Cincinnati, ishi.buffam@uc.edu and <sup>2</sup>Northern Kentucky University

## Introduction

Water resource issues in Cincinnati, OH, are issues common to many cities of the region: frequent pollution release to rivers during storm events due to an overburdened combined sewer-stormwater system, and nutrient loading from urban and agricultural watersheds causing surface water eutrophication. Green (vegetated) roofs are a component of green infrastructure gaining traction in US cities, with known benefits including stormwater retention and improved energy efficiency. Currently however, little is known about the potential for green roofs to provide direct nutrient removal/retention for the water passing through them.

Our group carries out interdisciplinary research on the biogeochemical function of green roofs, including services like nutrient retention/removal and carbon sequestration, but also potential dis-services like nutrient and metal leaching, and greenhouse gas emissions. Here we present results on nutrient and metal concentrations in runoff from green roofs.



Fig. 1. Sloped green roof at Civic Garden Center of Greater Cincinnati, used for monitoring of runoff water quality on full-scale roof.



Fig. 2. Experimental plots at Cincinnati Center for Field Studies, used for monitoring runoff water quality at plot-scale.

## Methods

We use a combination of experimental test roof plots, monitoring of existing roofs, and modeling to upscale results and put them in the context of city water resources. In this study we present results from three studies:

1. **Monitoring of runoff water quality** from a 50 m<sup>2</sup> sloped extensive green roof from all rain events for 18 months (N=71), together with a shingled "traditional roof" control and incoming precipitation water quality.
2. Runoff water quality from twenty-four small (1' x 2') plot-scale green roof microcosms from four rain events during Aug-Sept 2011. Treatments including varying plant types but all are averaged together here.
3. **Leachate water quality from common green roof growth medium components** used in the plot-scale experiments including: sand, heat-expanded shale, heat-expanded clay, mushroom compost, and Canadian peat.

## Results 1: Nutrients in runoff from full-scale green roof (average of 71 rain events)

Bottom Line: Ammonium concentrations were unchanged, but both Nitrate and Phosphate were leached out of the full-scale green roof at high concentrations during rain events.



Fig. 3. Runoff water quality measurements taken at downspout of traditional shingled roof (left) and green roof (right).

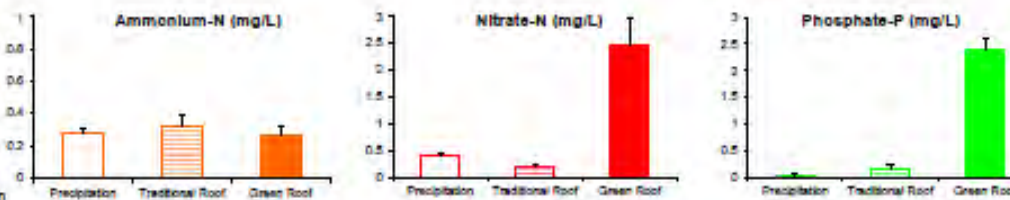

## Results 2: Nutrients in runoff from plot-scale experiment (average of 24 plots during 4 rain events)

Bottom Line: In the small-scale green roof plots, Nitrate concentrations in runoff were reduced but Phosphate and particularly Ammonium leached out during rain events.



Fig. 4. Runoff water quality measurements taken from buckets draining plots after each rain event.

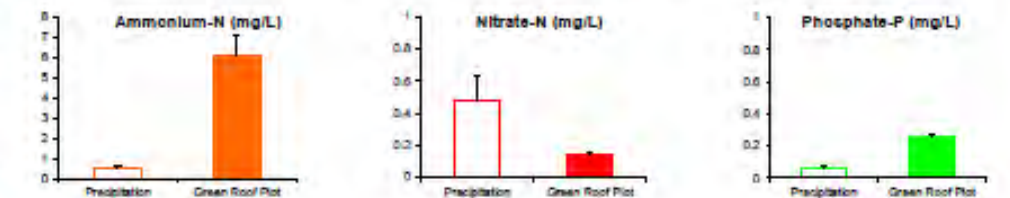

## Results 3: Nutrients in leachate from individual growth medium components

Bottom Line: In laboratory experiments, different growth medium components were responsible for leaching out different nutrients: Peat for Ammonium and Compost for Phosphate. Nitrate leaching was minimal.



Fig. 5. Individual growth medium components were leached (10g substrate in 100mL deionized water) in the lab.

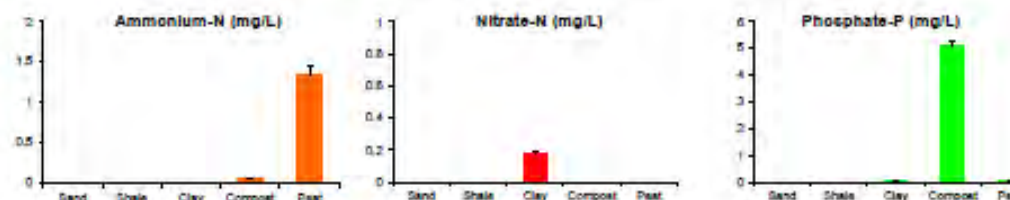

## In the Pipeline: Newly Installed Continuous Flow Measurements

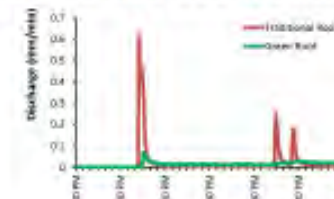

Fig. 6. Continuous runoff water quantity measurements have recently been added and will be used to calculate input/output budgets for all water quality parameters for green roof and control roof. Figure shows installation (left), their weir with pressure transducer (middle) and sample data from a rain event (right).

## Results 4: Water quality of runoff: Metals, salts and organic carbon

Analyte	Units	Precipitation	Traditional Roof Runoff	Green Roof Runoff
pH	pH units	5.7	6.5	7.0
Conductivity	µS/cm	22	53	232
DOC	mg/L	5	12	34
Ca	mg/L	1.1	4.5	24.8
K	mg/L	0.6	2.3	10.1
Mg	mg/L	0.2	0.6	4.8
Na	mg/L	0.3	0.4	2.3
Ag	µg/L	4.7	4.1	4.1
Al	µg/L	bd	3.9	32.9
Cd	µg/L	bd	194.3	16.0
Cu	µg/L	bd	67.0	61.5
Mn	µg/L	5.8	18.7	6.2
Zn	µg/L	27.2	372.9	952.9

Average concentration values for precipitation, traditional roof runoff and green roof runoff at the full-scale roof (N=71) rain events during 18 months for water quality parameters. See "Results 1" panel for values for inorganic nutrients. DOC = dissolved organic carbon, bd = below detection limit. Green roof values are shown in red when significantly higher, blue when significantly lower than traditional roof values for the given parameter (ANOVA,  $\alpha=0.05$ ).

## Summary

- Green roofs released inorganic nitrogen and very high levels of inorganic phosphorus (a disservice), as well as dissolved organic carbon and common ions, while reducing some trace metals like Copper and Manganese.
- Different growth medium components were responsible for the high P and N concentrations in runoff from our plot-scale experiments. The direct impact of green roofs on downstream water quality is thus highly variable, in large part related to variations in green roof substrate.
- Understanding and managing the impacts of green roofs on urban water resources requires a comprehensive evaluation of the relationship between green roof composition and biogeochemical function. We recommend exploring use of growth medium with a more balanced nutrient stoichiometry, to provide a means of both sustaining healthy plant growth and minimizing any negative water quality effects.

## Acknowledgements

Thanks to the great work of Jill Bader and Kathleen Hurley who ran the plot-scale experiment, and to Scott Niebing and Scott Licard who got the Civic Garden Center roof project and Leachate projects up and running. Thanks to the Ryan Mooney-Bullock and the Civic Garden Center for their incredible cooperation and the use of their sloped green roof for our monitoring project. Many others in our research group contributed to this project: Denis Bailey, Dan Divoiloss, Kate Johnson, and Mark Mitchell. Thanks to Jennie Russell and Dorn Boccelli for collaboration and advice about green roof research, and to David Hart and Tremco for supplying information about the green roof installation.

***Pervious Pavement and Pavers***

There are 6 types of parking surfaces at the Center. These types are the following:

1. Porous Asphalt
2. Pervious Concrete
3. Concrete
4. Permeable Pavers
5. Permeable Pavers
6. Permeable Pavers
7. Bioswale

These surfaces are being monitored by Urbanalta. Each one of the above mentioned parking surfaces has a separate sensor and the data from each sensor is being transmitted to a “cloud” database. This data can be queried and downloaded for analysis. Additionally, there is a weather station on site that measures different parameters such as precipitation.

Urbanalta Technology provided volume and flow time series data for the rain gauge and different surfaces for 2012. The data was stored on a web service. Each data stream started in late February and ended when the data was retrieved from the web service via query strings in late December. These time series reported data as frequently as each minute. Prior to analyzing the data, these large datasets were processed by MSD staff in Microsoft Excel to remove all data points with no recorded volume or flow. Examining only the non-zero values reduced the total number of data points from over 2,000,000 to less than 65,000, expediting data manipulation.

Once the time series was reduced to only the non-zero values, storm events were identified, tabulated, and plotted for each paver type, as graphed in Figure 2. Plotting overflow volume versus rain depth allows for qualitative comparisons between paver types. The Bioswale data set represents outflow from the Bioswale, which is receiving the overflow from all of the pavement systems. For example, Permeable Asphalt typically produces less overflow volume for a given rain depth than other paver types.



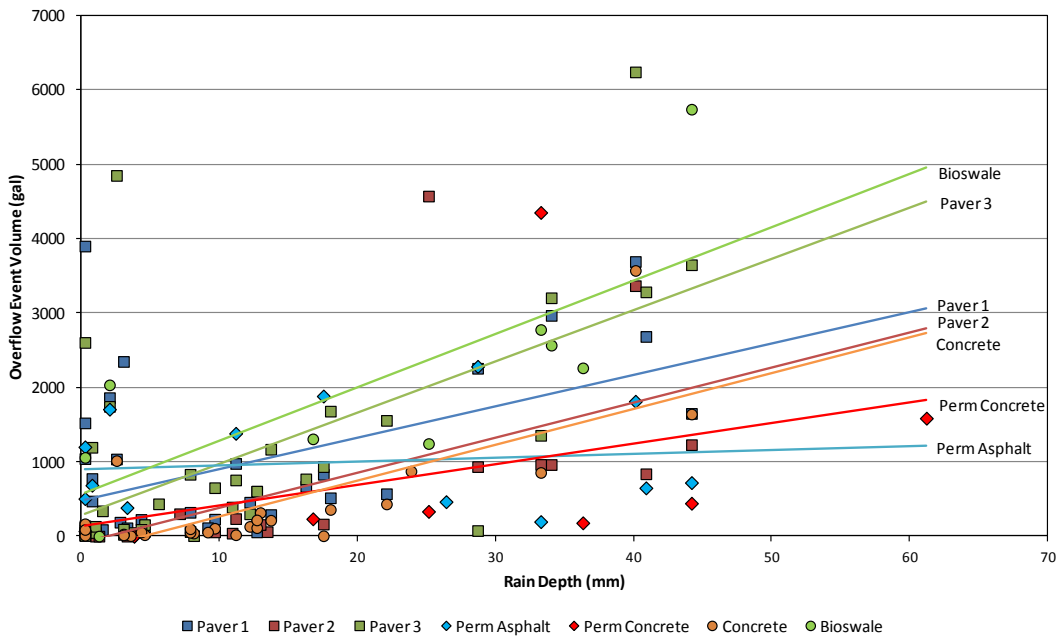

**Figure 2: Overflow Volume versus Rain Depth**

Not every paver type produced an overflow event for a given rain event. Rather than focusing on specific data points, similar data points can be grouped into regions which describe general paver behavior. Figure 3 is annotated to include these groups. By looking at which pavement types tend to fall in which groupings, you can learn a bit more about how each one is performing according to the current monitoring infrastructure.

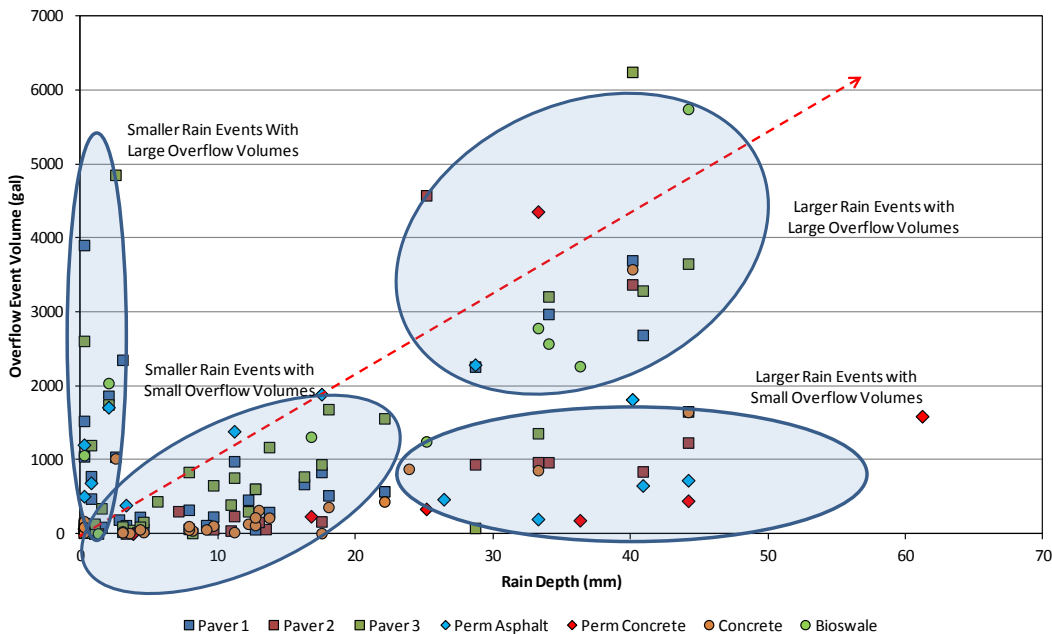
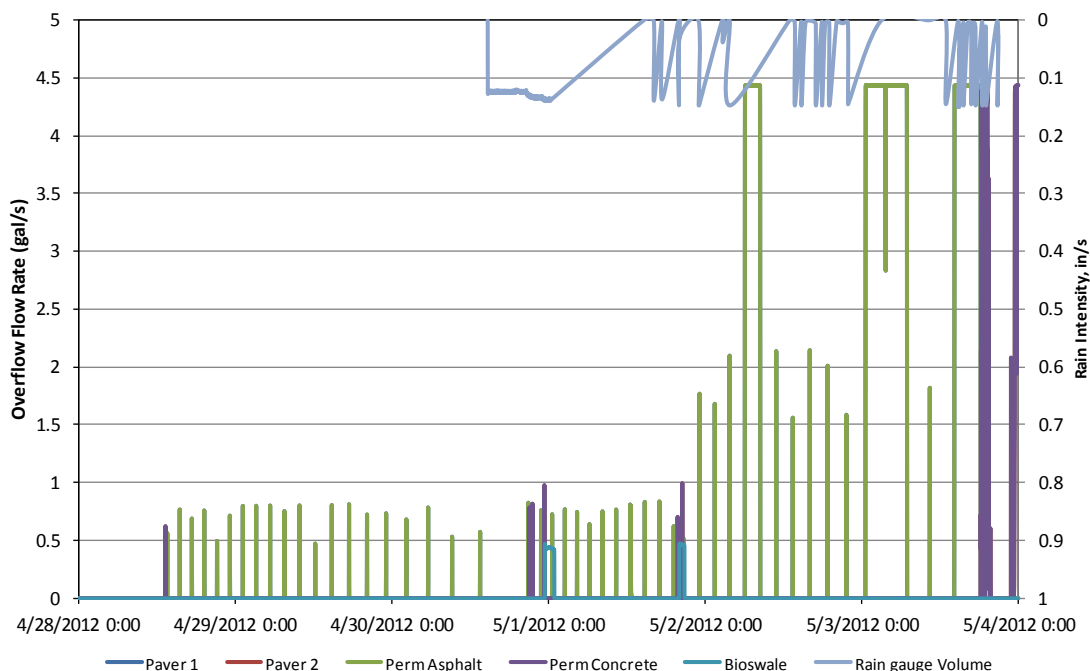

**Figure 3: Overflow Volume versus Rain Depth, with similar regions of paver performance grouped together.**

A recognized potential weakness in analysis based on overflow volume versus rain event depth is that rain intensity is not accounted for. Storms with varying hyetographs (distribution of rainfall over time) will induce different overflow responses, even if total rainfall depth is constant. Additionally, the available storage capacity within the pavement bed or in the catch basin itself influences how quickly the pavements begin to

overflow. To help correct for these factors, the overflow responses from each pavement were plotted for specific rain events using the provided flow rate data streams. Figure 4 plots the pavement overflow response for an example storm event. The graph appears as individual bars rather than a continuous flow because the data is collected through a pump that purges the water, turns off and then purges again once the water level reaches a certain height.

The flow rate time series of Paver 1 and Permeable Asphalt demonstrate nearly identical responses to each other (making it difficult to see both colors on the graph), as do Paver 2 and Permeable Concrete. Both the Paver 3 and Concrete flow rate time series were missing data during this storm event. The Bioswale triggered an overflow only twice.



**Figure 4: Paver response for example storm event.**

### ***Observational Evidence and Plans for Improving the System – GLC Team***

While the analysis of the pavement data for individual rain events and overall patterns observed over the course of a year provides useful information, it does not represent a complete picture of the performance of these systems. GLC team must pair what the data is revealing with what is observed on the surface during rain events. Unfortunately up to now the team has not had a consistent way to make surface observations given the unpredictable and sometimes inconvenient timing of rain events. Until the team has improved monitoring infrastructure to capture these missing data points, the team takes advantage of rain events to observe the systems in action. For example, Pervious Asphalt seems to absorb the most rain given that there is less water overflowing from the system. However, during recent observations in heavy rain events, a large portion of the surface area is generating sheet flow, causing water to pool at the downslope end of the pavement and drip into the manhole lid. Part of our upcoming work is to better understand why Pervious Asphalt's data appears as it does given what we have observed during rain events.

Concrete is another surface whose data needs illumination: it is not appearing in the data as producing the highest overflow volume of the pavements even though it is the only impervious surface in the study. We have started to make observations during rain events to determine if any rain is moving from the concrete surface onto other pavements. During at least three rains in the summer of 2013, rain was observed sheet flowing from the surface of Concrete onto Paver 1. This would affect the data in two ways: Concrete

overflow would be represented in the data lower than the amount of stormwater actually running off of it; Paver 1 overflow would appear higher in the data because of the input of water other than rain falling on the surface. This problem should be corrected by raising the curb between the two pavements, preventing surface runoff from leaving the Concrete.

Paver 3 has presented itself as an outlier in many ways. It is the one pavement that has a different shape and grading than the other five. It is located under trees that shed a large amount of fine organic matter. It seems to be plumbed in such a way that water from another part of the site is leaking into its catch basin in a way that has not responded to attempts at modification. For these reasons, it appears to be behaving quite differently than the other pavers, and is being removed from the flow analysis study.

The team is working to improve the monitoring system to address two factors that are currently difficult to account for: the height of water in the catch basins at the onset of a rain event and sheet flow versus direct percolation. When a rain event ends, there may be different amounts of water in the catch basins depending on when their pumps were last triggered. In order to start the next rain event with consistent water levels in all of the catch basins, the pumps must be manually triggered by a person climbing down into the manhole. This rarely happens. Ideally, we would add the capability of the pump to automatically purge the catch basins in between rain events, but are still determining a method by which this can happen efficiently and consistently.

Because all water falling on the pavement makes its way into the catch basin, either via the pipe draining the gravel bed or through the top of the manhole lid, we cannot distinguish how much water drained through the pavement surface and gravel and how much ran off the surface and directly into the manhole. To illuminate this difference the team will implement two additions to the monitoring infrastructure in the second half of 2013. Video cameras mounted to the front of the Green Learning Station building will capture images of the pavement surfaces, which can be analyzed by algorithm and the human eye, to determine the presence of sheet flow on the surface. Image based flow sensors will be installed in the catch basins to measure the amount of water flowing into them from the pipe draining the pavement gravel bed. Both of these data sets will supplement the existing pump-based flow and volume data.

In the future the team hopes to add periodic infiltration testing to measure how clogged each pavement type becomes over time. We are also interested in exploring water quality flowing off of each pavement type.

### **Cincinnati Museum Center (Union Station)**

Cincinnati Museum Center green roof is one of the projects that is being monitored live for both its condition and its stormwater runoff. The Museum has a live webcam installed on the roof that looks over vegetation. The link to this webcam is <http://www.cincymuseum.org/union-terminal/green-roof-camera> and its screen shots get refreshed automatically every 30 seconds. This webcam is also used by the public as an educational tool about green infrastructure. Below is a snapshot of the roof's website.

Home / Explore the Center / Systems & Exhibits / Union Terminal / Green Roof Camera

### Explore the Center

**SPECIAL EXHIBITS**

- Dead Sea Bioreactor: Life and Death in Ancient Times
- The Artistry of Bookbinding
- Retrospective of a Grassroot God
- Treasures of the Natural World

**MUSEUMS & ATTRACTIONS**

- CINCINNATI Theater
- Cincinnati History Museum
- U.S. Energy Children's Museum
- Museum of Natural History & Science
- Cincinnati History Library and Archives
- Genealogy Collections & Research Center

**The Edge of Appalachia**

**Union Terminal**

- Order Out of Chaos
- Temple to Transportation
- Reinvention
- Destiny to the City
- Act of Union Terminal
- Experience Union Terminal
- Green Roof Camera
- Presidential Visits

**FUNTIME & ACTIVITIES**

## Green Roof Camera



In 2010, a plant-covered, 7,650-square-foot green roof was installed at Cincinnati Museum Center as part of a \$10-million restoration of Union Terminal's Cincinnati Dining Room and Historic Dining Rooms.

Green roofs have many benefits: They absorb rainwater, provide insulation and help lower urban air temperatures. The roof of installing a green roof is equivalent to installing a 30-year-old roof. A green roof was selected because of the environmental benefits and evidence that shows the roof type lasts longer and stays in better condition than a traditional roof.

The restoration project, known as Project T, was the final major phase of the total renovation of Union Terminal. Project T also included the repair of roofing, steel columns, masonry, window lintels, windows and building systems and the restoration of major fixtures and modern Plaster Schumaker murals to their original color. Without Project T, damage to historic Union Terminal would have only grown worse and more expensive. With these renovations, Museum Center continues to support the interpretation of the Union Terminal building as its largest artifact.

Project T was graciously funded by multiple sources including a portion of the 2004 levy approved by Hamilton County voters, the State of Ohio through the Ohio Cultural Facilities Commission, the City of Cincinnati, Metropolitan Sewer District, National Endowment for the Arts, National Park Service through their Save America's Treasures Grant, an in-kind donation from Sorbix Vantage Company, in memory of Marc Sorbix and an anonymous donation.

Urbanalta, a research and development startup company; is exploring a new technology to measure the effectiveness of green infrastructure. The company is utilizing an innovative sensor imaging technology to measure the flow being released from the green roof after rain events. Urbanalta is working with USEPA to calibrate/validate their technology. Urbanalta did not get to the point of having calculated flow volumes from the CMC green roof to do an effectiveness performance analysis of the green roof.

## Washington Park

In Washington Park, as part of monitoring the green infrastructure performance, a network of transducers was installed in the dry wells to measure the stormwater runoff going through the system. When this park was constructed, MSD entered into an agreement with Parks to collect and download the data from these transducers periodically.

Recently the weather station that was placed on top of the 3CDC building got moved to the park's perimeter. This will increase the accuracy of the collected rain data. Also it will ease the accessibility to the station by Parks' personnel.

The transducers that were installed in the dry wells were not surveyed properly prior to installation. In order to utilize the available data and resources efficiently from this site, and to have consistency in the data collection and analysis throughout the different monitoring installations, MSD requested from USGS to submit a proposal. This proposal will cover the needed resources to effectively install, operate, collect and analyze the data from this site.

## Cincinnati Zoo and Botanical Gardens

### **Main Entry**

There are 2 on-site monitoring efforts at the zoo. One effort is monitoring the effectiveness of the green infrastructure and the 2<sup>nd</sup> effort is the in-pipe flow monitoring. The green infrastructure monitoring is taking place at 2 locations within the zoo. The 1<sup>st</sup> location is at the main entrance monitoring the pervious pavers system. The 2<sup>nd</sup> location is at the African Savannah where USGS is monitoring the ground water.

The main entrance monitoring effort was initiated by the Ohio State University. They installed 3 transducers in the dry wells through the pervious pavers system. These transducers were installed in 2011. There were 3 transducers placed in 3 dry wells. The dry wells location from upstream to downstream is beside the bathroom at the main entrance, at the main entrance gate, and the last one is beside the ticketing office. The transducers were programmed to collect and record the data every minute. Due to this short period of data recording, the transducers quickly reached data limits. For example, the transducers were installed in February and were full by July.

In December of 2012, these transducers were retrieved from the dry wells and the data was downloaded to conduct QA/QC and data analysis. First, the data needed to be corrected by adjusting for the barometric pressure. The pressure recorded by the transducer was corrected using the pressure recorded by the weather station on site. After correcting and evaluating the data and assistance from USGS, it was found that the stormwater depth data was not useful and could not be utilized to make a sound conclusion. The transducers were installed correctly by USGS in Q3 2013 and the data retrieval and analysis will start Q1 2014.

Additionally, a robust monitoring plan was not put in place to establish a comprehensive understanding of the entire drainage area at the main entrance. This means that the mass balance from the site could not be achieved because the flow from the pavers goes into a cistern. This cistern does not have a transducer and the zoo is not operating it in an efficient way. Therefore, the analysis for this site could not be completed.

In Q3 2013 transducers were installed correctly at the site based on the schematic below. The in-pipe flow monitor downstream of the cistern will get reinstalled in order to establish the stormwater runoff mass balance for this site to measure the effectiveness of this green infrastructure.

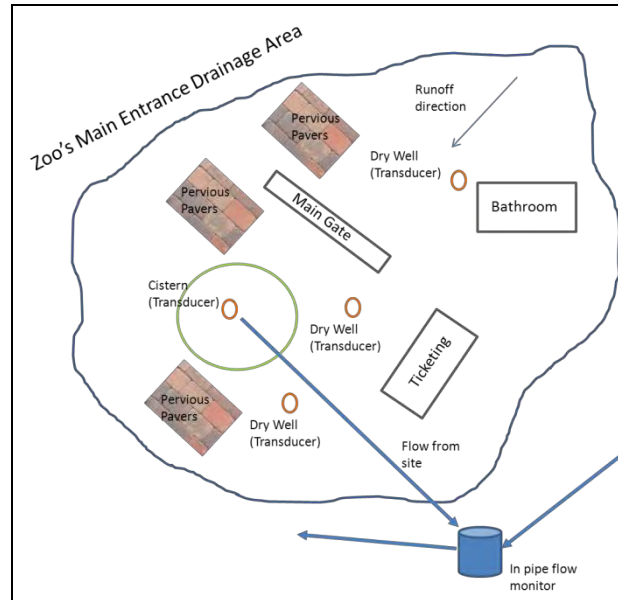

Monitoring at Cincinnati zoo main entrance

The in-pipe flow monitoring data at the zoo's main entrance was analyzed by Dr. Robert Pitt from the University of Alabama (The study is available upon request). This analysis is part of a project to measure the effectiveness of the green infrastructure installations at three sites, the Zoo, Cincinnati Sate and Clark Montessori. The evaluation of the retrofitted green infrastructure stormwater controls for this site consisted of analyzing the in-pipe flow and calculating the stormwater contribution from the site before, during and

after construction. The analysis showed that at the Cincinnati's Zoo main entrance, the stormwater runoff volume was reduced by 80% from the pre-construction values.

### ***African Savannah***

The ground water monitoring at the African Savannah project site that is being conducted by USGS has been at a steady state over the last year. In other words, there has not been a fluctuation in the groundwater levels at the site. Now that construction is complete, the impact on the ground water monitoring will be evaluated by USGS. As part of the in-pipe flow monitoring study, the African Savannah has shown 70% reduction in the stormwater runoff volume.

The analysis results are promising and demonstrate the effectiveness of green infrastructure in reducing stormwater runoff. Additionally, once the data from the transducers gets analyzed then the system can be evaluated holistically.

### **Cincinnati State Technical Community College**

Cincinnati State Technical Community College is one of the comprehensive stormwater control sites in Cincinnati. It has different green infrastructure controls (pervious pavers, bioinfiltration basins, level spreaders, etc). These stormwater controls were installed in 3 phases. The control trains from each element are connected to one another, making this site very unique in terms of monitoring. The performance of these controls can be evaluated as a system from upstream to downstream until it gets into the combined sewer.

MSD entered into an agreement with USGS and US EPA to install monitors at the site to evaluate the performance of the green infrastructure. These monitors are going to be installed in November 2013. Currently, as part of a separate effort, US EPA has monitors on site to evaluate the pervious pavers. The data generated from this site is currently in the analysis and modeling phase.

Until the onsite monitoring (control specific) takes place, MSD evaluated the in-pipe flow monitoring data. This evaluation was part of the study mentioned above by Dr. Pitt. The results from this evaluation indicated that the southern area that consisted of bioinfiltration basins and rain gardens reduced the stormwater runoff volume by 85%. Similar to the Zoo's site, once the monitoring results of the specific green infrastructure is combined with the in-pipe flow monitoring, a holistic understanding and evaluation can be obtained.

### **CPS Clark Montessori High School**

The CPS Clark Montessori High School green infrastructure site is being monitored with in-pipe flow monitoring. The flow monitoring meter is placed in the combined sewer system. The Clark Montessori site has many types of green infrastructure. Some of these are being monitored individually by US EPA. The in-pipe monitoring data is being analyzed as part of the UA study mentioned above. The data analysis for this site is challenging due to the connectivity of the different elements and the drainage area. During analysis, many parameters and assumptions have to be considered in order to evaluate the effectiveness of the installed systems. This uncertainty in the analysis increases as the drainage area and number of elements increases.

As part of the green infrastructure effectiveness study, the pre and post construction in-pipe flow was analyzed. The evaluation results demonstrated that the post construction flow is 20% less than the preconstruction flow.

## 6. Project Summaries

A project summary has been created for each project. These summaries are presented as stand-alone summary sheets that can be modified as necessary to incorporate new information. Summary sheets for each of the enabled impact projects are included as **Attachment B** to this document. An example of a summary sheet is presented in Figure 2.

The summary sheets are intended to provide the reader with a basic understanding of the project, its status, location, setting, green infrastructure, project benefits, MSD funding levels, and current monitoring. “Lessons learned” are indicated where appropriate. The summaries also include a project location map, a graphic showing the location and types of green infrastructure, design and layout schematics, and relevant photographs.

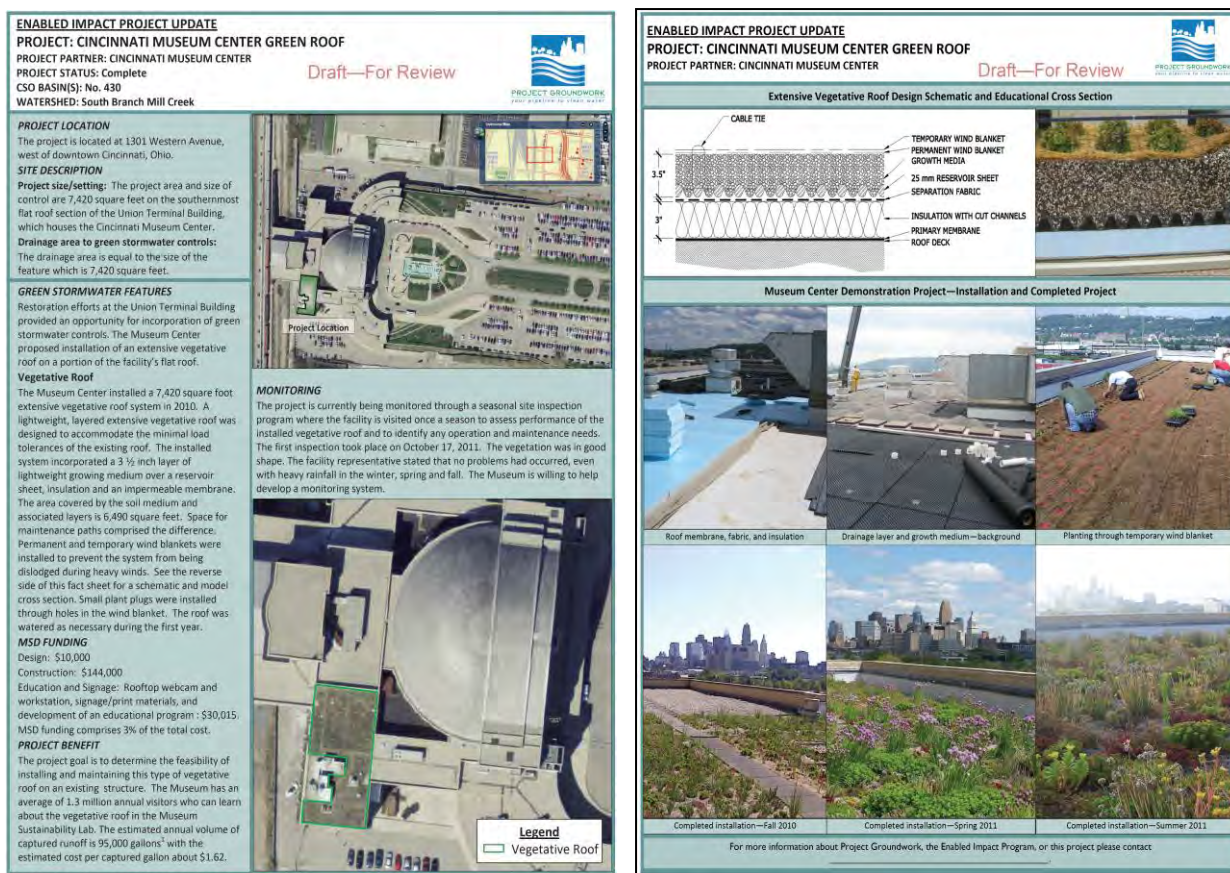

Figure 2: Sample project summary sheets

**ATTACHMENT A: MAINTENANCE SUMMARY SHEETS**





**Metropolitan Sewer District of Greater Cincinnati  
Post-Construction BMP Site Evaluation  
MAINTENANCE SUMMARY-ALL SITES**

**American Red Cross**

<u>Visited</u>	<u>Type</u>	<u>Maintenance Need</u>	<u>Location</u>	<u>Maintenance Complete</u>	<u>Date Complete</u>
#####	Bioinfiltration	Continue efforts to control invasives.	Vegetation	<input type="checkbox"/> Yes	
		Mulching swale would help retain soil moisture, improve plant health, and make plants less susceptible to being overtaken by invasives.	Soil Media	<input type="checkbox"/> Yes	
		Clean leaf accumulation out of swale.	Soil Media	<input type="checkbox"/> Yes	

**Cincinnati State Technical & Community College - Front Drive**

<u>Visited</u>	<u>Type</u>	<u>Maintenance Need</u>	<u>Location</u>	<u>Maintenance Complete</u>	<u>Date Complete</u>
#####	Pervious Pavement	Several areas of ponded water on surface of permeable pavers. Pavers need restorative vacuuming.		<input type="checkbox"/> Yes	

**Cincinnati State Technical & Community College - Lot C**

<u>Visited</u>	<u>Type</u>	<u>Maintenance Need</u>	<u>Location</u>	<u>Maintenance Complete</u>	<u>Date Complete</u>
#####	Other Feature	Fill in gully and stabilize slope.	Contributing Drainage Area	<input type="checkbox"/> Yes	
#####	Pervious Pavement	Large areas of ponding water; all pervious pavement areas need to be vacuumed		<input type="checkbox"/> Yes	
#####		Pavers need restorative maintenance vacuuming		<input type="checkbox"/> Yes	
		Weeds growing between pavers is a sign of excessive clogging; spray weeds and remove to keep additional organic debris from clogging system		<input type="checkbox"/> Yes	

**Cincinnati State Technical & Community College - Lot D**

<u>Visited</u>	<u>Type</u>	<u>Maintenance Need</u>	<u>Location</u>	<u>Maintenance Complete</u>	<u>Date Complete</u>
#####	Pervious Pavement	Pavers need restorative maintenance vacuuming.		<input type="checkbox"/> Yes	

**Cincinnati Zoo & Botanical Garden-Main Entry**

<u>Visited</u>	<u>Type</u>	<u>Maintenance Need</u>	<u>Location</u>	<u>Maintenance Complete</u>	<u>Date Complete</u>
#####	Pervious Pavement	Permeable pavers are clogged and in need routine cleaning.		<input type="checkbox"/> Yes	

**Clark Montessori High School (CPS)**

<u>Visited</u>	<u>Type</u>	<u>Maintenance Need</u>	<u>Location</u>	<u>Maintenance Complete</u>	<u>Date Complete</u>
----------------	-------------	-------------------------	-----------------	-----------------------------	----------------------

#####	Bioinfiltration	Weeds (specifically the nutsedge) growing the bioswale needs to be sprayed. Nutsedge is a very aggressive invasive and will spread rapidly if not controlled.		<input type="checkbox"/> Yes
#####	Pervious Pavement	All permeable pavement (paver and concrete parking lots, paver courtyard, and concrete walkway) should be vacuumed (standard 2x/yr) to clear sediment and maintain infiltration.		<input type="checkbox"/> Yes

### Comer Alley - DOTE Pervious Alleys

<u>Visited</u>	<u>Type</u>	<u>Maintenance Need</u>	<u>Location</u>	<u>Maintenance Complete</u>	<u>Date Complete</u>
#####	Pervious Pavement	Vaccum/sweep pavers to clear debris and sediment; manage the weeds that are growing between the pavers.		<input type="checkbox"/> Yes	
		Clear litter and debris out of inlet in southeast corner of alley.	Outlet/Overflow Spillway	<input type="checkbox"/> Yes	

### Evanston Aquatic Center

<u>Visited</u>	<u>Type</u>	<u>Maintenance Need</u>	<u>Location</u>	<u>Maintenance Complete</u>	<u>Date Complete</u>
#####	Bioinfiltration	Replace/repair damaged cleanout cap to prevent debris from entering/clogging underdrain.		<input type="checkbox"/> Yes	
#####	Pervious Pavement	Permeable concrete needs to be cleaned. Using a vacuum truck is recommend over a mechanical sweeper, which can accelerate the deterioration of permeable concrete's surface and in turn create more sediment to clog the system.		<input type="checkbox"/> Yes	

### Habigs Parking Lot

<u>Visited</u>	<u>Type</u>	<u>Maintenance Need</u>	<u>Location</u>	<u>Maintenance Complete</u>	<u>Date Complete</u>
#####	Bioinfiltration	Clear debris/leaves out of curb cuts.	Stormwater Entry Point	<input type="checkbox"/> Yes	
	Pervious Pavement	Weeds are a sign of clogged pavers; weeds should be pulled to prevent further clogging.		<input type="checkbox"/> Yes	
		Pavers need to be vacuumed to restore permeability.		<input type="checkbox"/> Yes	

### Hartwell Elementary School (CPS)

<u>Visited</u>	<u>Type</u>	<u>Maintenance Need</u>	<u>Location</u>	<u>Maintenance Complete</u>	<u>Date Complete</u>
#####	Pervious Pavement	Keep organic debris (grass clippings, leaves, soil, etc.) off of surface of pervious concrete. As the debris breakdown, it will clogg the pervious pavement.		<input type="checkbox"/> Yes	
		Pervious concrete should be vacuum cleaned at least 2x year to maintain permeability.		<input type="checkbox"/> Yes	

### Immanuel

<u>Visited</u>	<u>Type</u>	<u>Maintenance Need</u>	<u>Location</u>	<u>Maintenance Complete</u>	<u>Date Complete</u>
#####	Bioinfiltration	The 3 inlet pipes need to be cleaned out.		<input type="checkbox"/> Yes	
		Continue to remove/control invasives.	Vegetation	<input type="checkbox"/> Yes	

## Oakley Square

<u>Visited</u>	<u>Type</u>	<u>Maintenance Need</u>	<u>Location</u>	<u>Maintenance Complete</u>	<u>Date Complete</u>
#####	Pervious Pavement	Once all the leaves have fallen for the season, clean leaf debris from surface of pervious concrete.		<input type="checkbox"/> Yes	
#####		Clean debris and sediment off surface of permeable concrete.		<input type="checkbox"/> Yes	

## Osborne Alley - DOTE Pervious Alleys

<u>Visited</u>	<u>Type</u>	<u>Maintenance Need</u>	<u>Location</u>	<u>Maintenance Complete</u>	<u>Date Complete</u>
#####	Pervious Pavement	Vaccum/sweep pavers to clear sediment and debris out of paver joints.		<input type="checkbox"/> Yes	

## Wyoming High School

<u>Visited</u>	<u>Type</u>	<u>Maintenance Need</u>	<u>Location</u>	<u>Maintenance Complete</u>	<u>Date Complete</u>
#####	Bioinfiltration	Control invasives growing in basin (clover, johnsongrass, etc.)	Vegetation	<input type="checkbox"/> Yes	
		Stabilize soil on surrounding slopes, clean any eroded sediment out of basin.	Contributing Drainage Area	<input type="checkbox"/> Yes	
		This winter, once all of the plants have been cut back, mulch the basin.		<input type="checkbox"/> Yes	

## **ATTACHMENT B: PROJECT SUMMARIES**

## ENABLED IMPACT PROJECT UPDATE

### PROJECT: AMERICAN RED CROSS OF GREATER CINCINNATI

PROJECT PARTNER: AMERICAN RED CROSS

PROJECT STATUS: Complete

CSO BASIN(S): No. 549

WATERSHED: Duck Creek



#### PROJECT LOCATION

Located in along the I-71 corridor in Cincinnati, Ohio. The site is bound by I-71 on the southeast and Evanston Avenue on the west. See map at right.

#### SITE DESCRIPTION

**Project size/setting:** Site area is 2.10 acres with a matching disturbed area. The project is in an urban/urban residential area and was built on existing residential and vacant land.

**Drainage area to green infrastructure:** 94,690 square feet of rooftop and surface runoff

#### GREEN INFRASTRUCTURE FEATURES

Stormwater features at the site include an extensive vegetative roof and a bioretention swale. These features were incorporated into the application for LEED certification for the Red Cross building when construction was completed in 2010.

##### Vegetative Roof

The vegetative roof is composed of a Green Grid® tray system. The trays contain 4 inches of soil media. These were chosen to accommodate the construction schedule for the site and the flexibility they provided. This roof was designed to retain roughly 57% of the stormwater during a 2-inch rain event. The tray system comprises approximately 62% of the sloped roof on the building. General maintenance of the plants will be required and, as needed, the growing medium may be replaced.

##### Bioretention Facility

The 12,000 square foot bioswale was installed along



the parking lot on the eastern side of the new Red Cross building. The majority of the feature lies within a highway right-of-way, although the access and cleanout structures are on American Red Cross property. There is a pre-treatment filter strip that is located along I-71 which assists in improving the water quality of the runoff prior to entering the feature.

#### MSD FUNDING

Design: \$22,300

Construction: \$146,927

Education and signage: \$8,000

The MSD funding comprised 1% of the total building construction cost.

#### PROJECT BENEFIT

A major benefit of this project is the educational opportunities available to the community through site tours, green infrastructure signage, and brochures. In addition, the plant selection makes it a Monarch Waystation, used to assist monarch butterflies in migration south for the winter months. Estimated annual volume of captured runoff is 978,000 gallons in a typical year<sup>1</sup> making the construction cost per captured gallon \$0.16.

#### MONITORING

Seasonal site inspections are conducted quarterly to assess long-term viability of the green controls and to identify potential operation and maintenance issues. Site visits are also being conducted after high intensity wet weather events to assess performance of the controls and where appropriate, overflow structures.



#### Legend

- Bioretention Facility
- Vegetative Roof

<sup>1</sup>The typical year used in this estimate assumes total annual rainfall of 41 inches.

**ENABLED IMPACT PROJECT UPDATE**

**PROJECT: AMERICAN RED CROSS OF GREATER CINCINNATI**

**PROJECT PARTNER: AMERICAN RED CROSS**



**Red Cross Green Infrastructure Features**

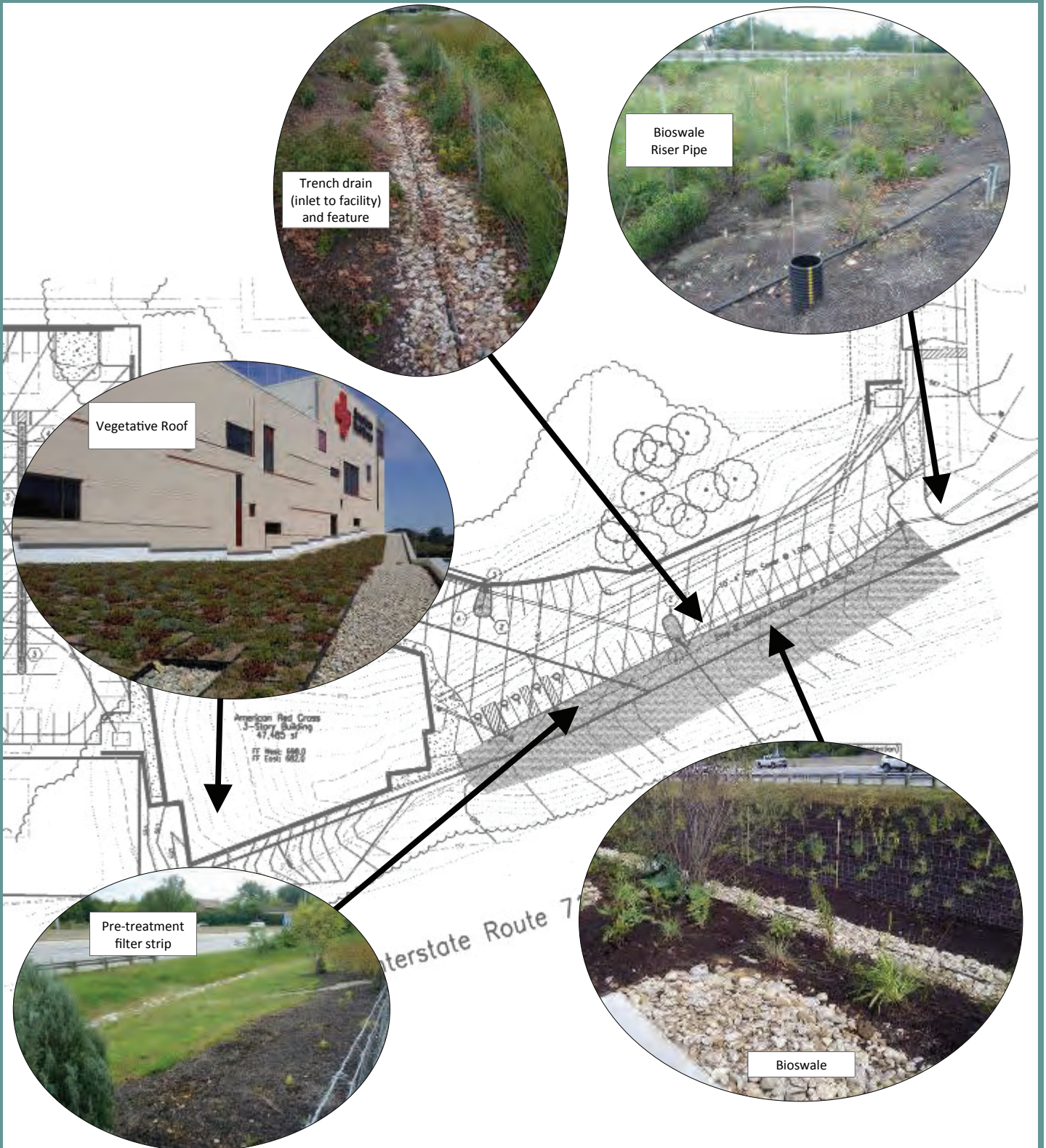

For more information about Project Groundwork, the Enabled Impact Program, or this project please email Lynn Lodor, Environmental Programs Manager at: [MaryLynn.Lodor@cincinnati-oh.gov](mailto:MaryLynn.Lodor@cincinnati-oh.gov) .

Mary-

## **ENABLED IMPACT PROJECT UPDATE**

### **PROJECT: AMERICAN RED CROSS OF GREATER CINCINNATI**

**PROJECT PARTNER: AMERICAN RED CROSS**



**Lessons Learned: Property ownership and permitting must be addressed prior to design completion. Adequate access to a feature is important for maintenance.**

The majority of the bioswale feature at the American Red Cross project is situated on interstate highway right-of-way. Access to a green feature must be maintained even when the site is owned by multiple entities. The feature is managed by the American Red Cross, and therefore during design, care was taken to ensure the underdrain was installed on American Red Cross property for ease of maintenance.

Permitting issues with the state after design completion resulted in major redesign of the bioswale feature. To keep the underdrain, and all other pipes and structures, on the Red Cross property, it was necessary to place the underdrain directly over the slotted drain that discharges water to the feature. The perforated underdrain was constructed as designed, directly below the slotted drain pipe.

While access to this pipe is still available whenever it may be necessary, hydraulically, the water does not always travel the width of the bioswale. In future designs, there should be careful consideration of parcel ownership prior to planning and design completion.



## ENABLED IMPACT PROJECT UPDATE

### PROJECT: Urban Water Grant –North Fairmount (Carll/Denham Ravine)

PROJECT PARTNER: Mill Creek Watershed Council of Communities

PROJECT STATUS: Currently in Design Phase

CSO BASIN(S): 10

WATERSHED: Denham



#### PROJECT LOCATION

The project is located along Denham Street between Linden and Beekman in the North Fairmount Community.

#### SITE DESCRIPTION

**Project size/setting:** The project area is approximately 100,000 square-feet in a residential area. The project site is just east of the CRC sprayground (see figure below).

#### Drainage area to green infrastructure:

The drainage area for all the green features on this site includes approximately 3.31 acres of wooded and developed residential area.

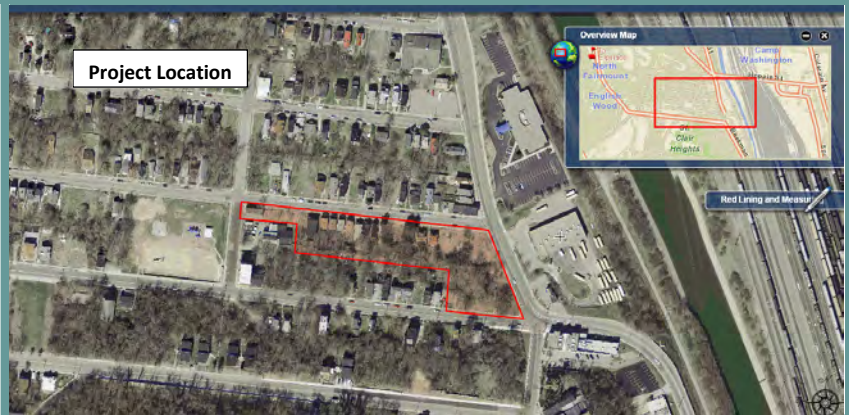

#### GREEN INFRASTRUCTURE FEATURES

The project involves installation of an enhanced bio-swale, planting, and educational signage. Construction of the conveyance includes approximately 3,000 cubic yards of earthwork and grading, approximately 60 linear feet of proposed storm sewer; and 1.3 acres of site stabilization, seeding and reforestation.

#### MSD FUNDING

Design Estimate: \$76,900

Construction Estimate: \$148,500

Grant Funds Awarded: \$72,000 (SWIF grant)

Operation and Maintenance: O&M of the installed green stormwater features will be provided by Cincinnati Park Board.

#### PROJECT BENEFIT

Conceptual designs estimate the total potential annual volume of runoff removed from the combined sewer system to be 0.20M gallons<sup>1</sup>.

#### MONITORING

Seasonal site inspections will be conducted by Cincinnati Parks Department (via an in-place MOU) to assess long-term viability of the green controls and identify potential operation and maintenance issues.

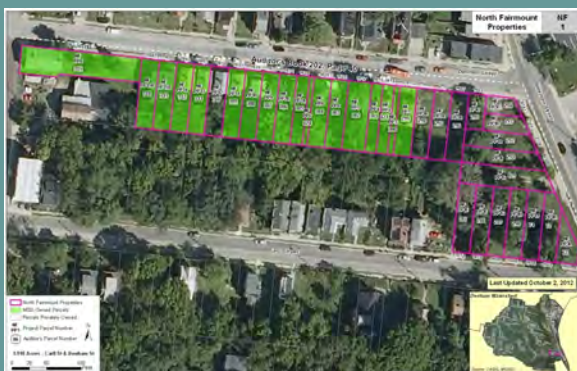

#### PROJECT STATUS UPDATE

The figure above details the properties affected. The green highlighted properties have been acquired by MSDGC to date. MSDGC is currently pursuing procurement of the remaining lots outlined in purple.

Board of County Commissioners approved 2013 design and construction funds for this project. Design is currently underway and construction legislation is anticipated for second quarter of 2014.

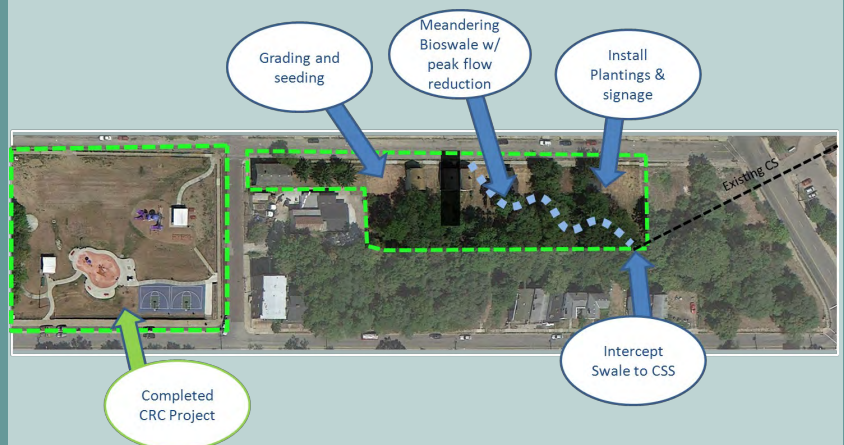

<sup>1</sup>The typical year used in this estimate assumes total annual rainfall of 41 inches.



## ENABLED IMPACT PROJECT UPDATE

### PROJECT: CHRIST HOSPITAL RAIN GARDENS

PROJECT PARTNER: THE CHRIST HOSPITAL

PROJECT STATUS: Removed

CSO BASIN(S): NO. 666

WATERSHED: Lower Mill Creek



#### PROJECT LOCATION

The project is located south of the Mason Street parking garage at The Christ Hospital facility. It is in the community of Mount Auburn which lies north of downtown Cincinnati, Ohio.

#### SITE DESCRIPTION

**Project size/setting:** The project area is a roughly 45,800 square feet, of which 50% is estimated to be impervious surfaces. The hospital is located in an urban residential setting.

**Drainage area to green infrastructure:** The drainage area is estimated to be 12,000 square feet.

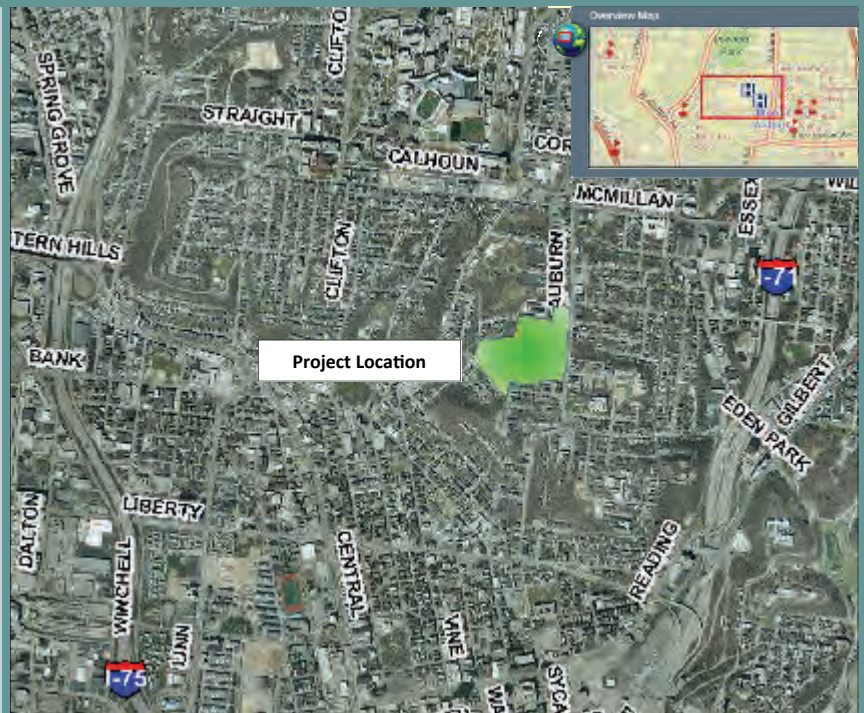

#### GREEN INFRASTRUCTURE FEATURES

At this project, three rain gardens, totaling 1,450 square feet, were installed in 2010.

#### Rain Gardens

Three interconnected rain gardens, installed in series, were placed between the roadway and parking garage on Mason Street. The upstream drainage area for this system includes runoff from the adjacent street, sidewalk areas, and landscaped areas. The third rain garden also collects surface runoff from a grassy swale that parallels the garage. There is an 8-inch underdrain which connects the first garden to the second and the second to the third. The underdrain in the third rain garden ties directly back into the combined sewer.

#### MONITORING

The project is being monitored through a seasonal site inspection program where the facility is visited quarterly to assess performance of the installed rain gardens and to identify any operation and maintenance needs.

#### NOTE

Due to Christ Hospital development and expansion, the rain gardens had to be removed. The new design currently accounts for 9,500 square feet of replacement rain gardens. This is more than six times the original size!

#### MSD FUNDING

Construction: \$20,000

The MSD funding comprised 56% of the total construction cost of the green stormwater control.

#### PROJECT BENEFIT

The project functions as a demonstration of small scale green controls in an urbanized institutional setting. It is intended to show property owners that green stormwater control need not take up a lot of valuable space.

The rain gardens are visible to pedestrians as well as cars entering the garage. In addition, the plant selection are those found in a Monarch Waystation, used to assist monarch butterflies in migration south for the winter.



<sup>1</sup>The typical year used in this estimate assumes total annual rainfall of 41 inches.

**Rain Garden Schematics and Installation**

**The Christ Hospital**  
**Mason Street Rain Gardens**  
**Layout Plan** **Scale: 1" = 20'-0"**

Viox Services, Inc. 15 W. Voorhees St., Cincinnati, Ohio 45215  
 513-679-3213 513-679-3312 fax August 2009

SHEET # L-4

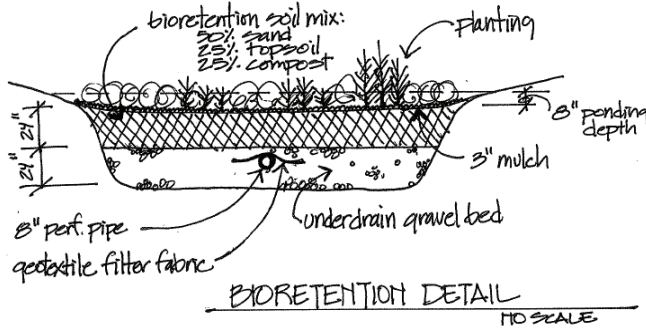

Note: All workmanship, methods and materials per CDOT and CMS standards.

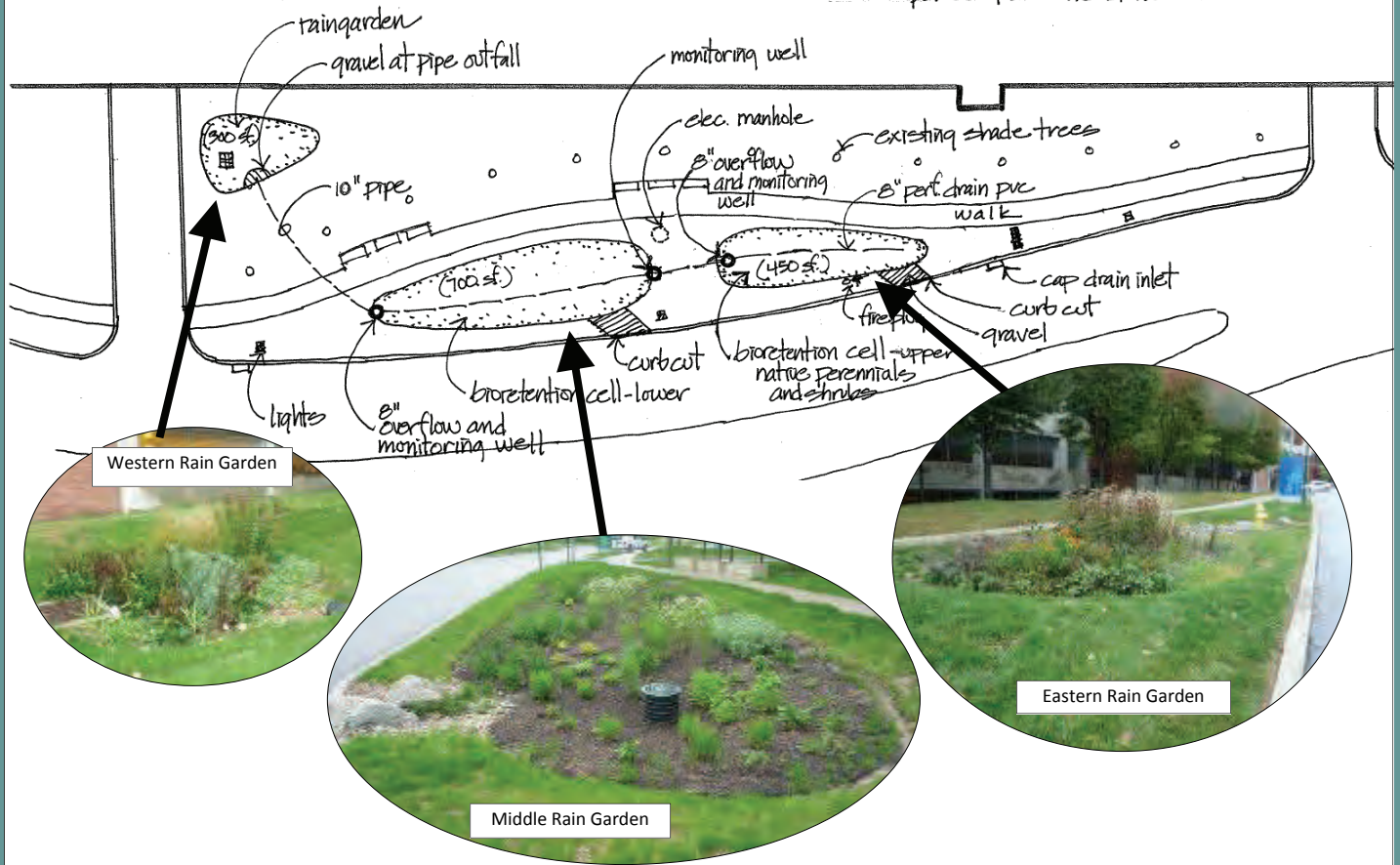

**Cross Section**

Viox Services, Inc. 15 W. Voorhees St., Cincinnati, Ohio 45215

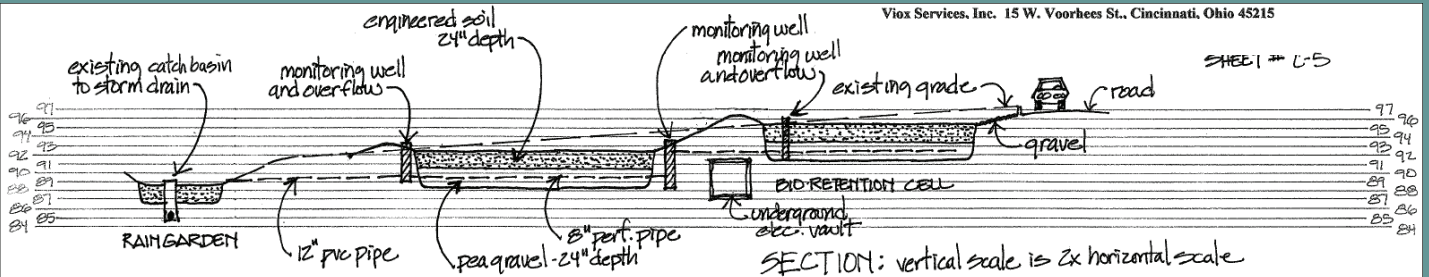

## **ENABLED IMPACT PROJECT UPDATE**

### **PROJECT: CHRIST HOSPITAL RAIN GARDENS**

**PROJECT PARTNER: THE CHRIST HOSPITAL**



***Lesson Learned: Green infrastructure should be designed to optimize the amount of stormwater draining to the facility.***

A significant amount of the stormwater runoff from the adjacent roadway bypasses both bioinfiltration basins at Christ Hospital, drains to a downstream inlet, and enters the combined sewer system. Designs should optimize stormwater runoff directed into the facility. Potential solutions include installing curb and gutter with a depression in the pavement to direct stormwater into the facility; placing the bioinfiltration basins further downstream adjacent to the existing inlet into the combined sewer system; or potentially installing a small “bump out” to help direct stormwater into the facility.



Christ Hospital rain garden during a rain event.

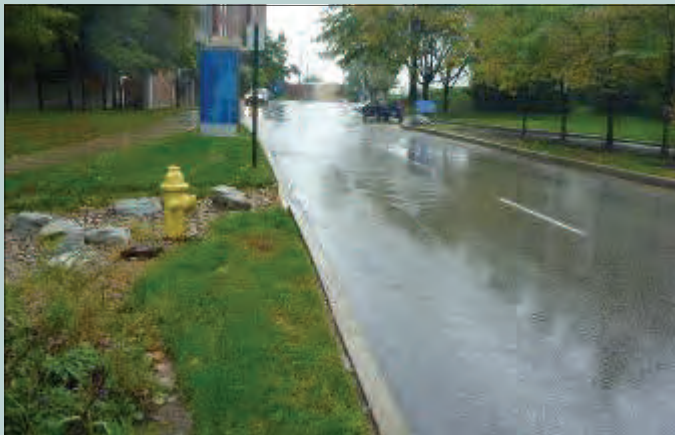

Stormwater runoff bypasses the curb cut to the rain garden.



Stormwater runoff enters the combined sewer system.

## ENABLED IMPACT PROJECT UPDATE

### PROJECT: CINCINNATI MUSEUM CENTER GREEN ROOF

PROJECT PARTNER: CINCINNATI MUSEUM CENTER

PROJECT STATUS: Complete

CSO BASIN(S): No. 430

WATERSHED: South Branch Mill Creek



#### PROJECT LOCATION

The project is located at 1301 Western Avenue, west of downtown Cincinnati, Ohio.

#### SITE DESCRIPTION

**Project size/setting:** The project area and size of control are 7,420 square feet on the southernmost flat roof section of the Union Terminal Building, which houses the Cincinnati Museum Center.

#### Drainage area to green infrastructure:

The drainage area is equal to the size of the feature which is 7,420 square feet.

#### GREEN INFRASTRUCTURE FEATURES

Restoration efforts at the Union Terminal Building provided an opportunity for incorporation of green stormwater controls. The Museum Center proposed installation of an extensive vegetative roof on a portion of the facility's flat roof.

#### Vegetative Roof

The Museum Center installed an extensive vegetative roof system in 2010. A lightweight, layered extensive vegetative roof was designed to accommodate the minimal load tolerances of the existing roof. The installed system incorporated a 3 ½ inch layer of lightweight growing medium over a reservoir sheet, insulation and an impermeable membrane. The area covered by the soil medium and associated layers is 6,490 square feet. Space for maintenance paths comprised the difference. Permanent and temporary wind blankets were installed to prevent the system from being dislodged during heavy winds. See the reverse side of this fact sheet for a schematic and model cross section. Small plant plugs were installed through holes in the wind blanket. The roof was watered as necessary during the first year.

#### MSD FUNDING

Design: \$10,000

Construction: \$144,000

Education and Signage: Rooftop webcam and workstation, signage/print materials, and development of an educational program : \$30,015. MSD funding comprises 3% of the total cost.

#### PROJECT BENEFIT

The project goal is to determine the feasibility of installing and maintaining this type of vegetative roof on an existing structure. The Museum has an average of 1.3 million annual visitors who can learn about the vegetative roof in the Museum Sustainability Lab. The estimated annual volume of captured runoff is 95,000 gallons<sup>1</sup> with the estimated cost per captured gallon about \$1.62.



#### MONITORING

Seasonal site inspections will be conducted quarterly to assess long-term viability of the green roof and to identify potential operation and maintenance issues. This project is also being monitored through the use of a live webcam for both its condition and its stormwater runoff. A research and development company is utilizing an innovative sensor imaging technology to measure the flow being released by the green roof following wet weather events.



<sup>1</sup>The typical year used in this estimate assumes total annual rainfall of 41 inches.

**ENABLED IMPACT PROJECT UPDATE**  
**PROJECT: CINCINNATI MUSEUM CENTER GREEN ROOF**  
**PROJECT PARTNER: CINCINNATI MUSEUM CENTER**



**Extensive Vegetative Roof Design Schematic and Educational Cross Section**

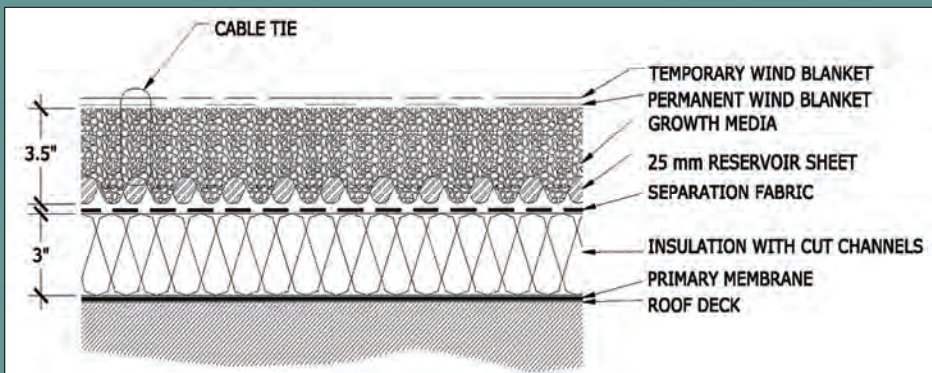

**Museum Center Demonstration Project—Installation and Completed Project**



Roof membrane, fabric, and insulation

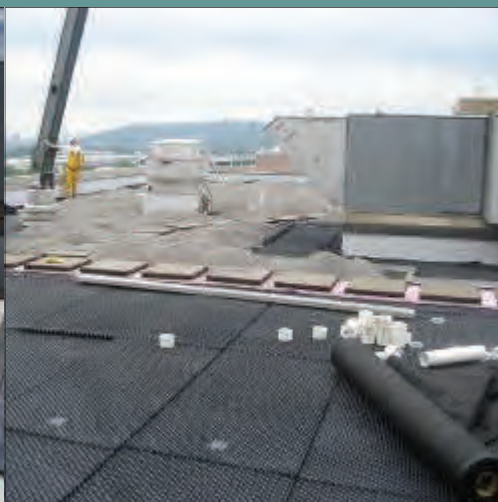

Drainage layer and growth medium—background



Planting through temporary wind blanket



Completed installation—Fall 2010



Completed installation—Spring 2011



Completed installation—Summer 2011

For more information about Project Groundwork, the Enabled Impact Program, or this project please email  
 Lynn Lodor, Environmental Programs Manager at: [MaryLynn.Lodor@cincinnati-oh.gov](mailto:MaryLynn.Lodor@cincinnati-oh.gov) .

Mary-

## **ENABLED IMPACT PROJECT UPDATE**

### **PROJECT: CINCINNATI MUSEUM CENTER GREEN ROOF**

**PROJECT PARTNER: CINCINNATI MUSEUM CENTER**



***Lesson Learned: Understand typical unit costs for green infrastructure before getting and approving bids.***

The original funding request for an 11,200 square foot extensive green roof was \$750,508, equivalent to a cost of approximately \$67 per square foot. The MSD project manager knew this was unreasonable and met with the applicant and their design team to discuss the high unit cost. The final funding request submitted by the applicant was \$183,602, equivalent to a cost of approximately \$16 per square foot. The final installation cost was less than expected, yielding a final cost per square foot of \$13.

Those interested in installing green roofs or other green infrastructure features may need more information related to typical costs, or more information on parameters that can be adjusted to minimize costs, which will allow green infrastructure to be more economically feasible.



Extensive vegetative roof at Cincinnati Museum Center.

**ENABLED IMPACT PROJECT FACT SHEET**

**PROJECT: CINCINNATI STATE CAMPUS**

**PROJECT PARTNER: CINCINNATI STATE TECHNICAL AND COMMUNITY COLLEGE**

**PROJECT STATUS: Construction Complete**

**CSO BASIN(S): NO. 21 AND NO. 12**

**WATERSHED: South Branch Mill Creek**



**PROJECT LOCATION**

Located just East of I-75 the project site is bound by Central Parkway to the North and West, and Ludlow to the East.

**SITE DESCRIPTION**

**Project size/setting:** The project site is a 40-acre technical and community college campus in an urban/urban residential area.

**Drainage area to green infrastructure:**

188,179 square feet of rooftop and surface runoff

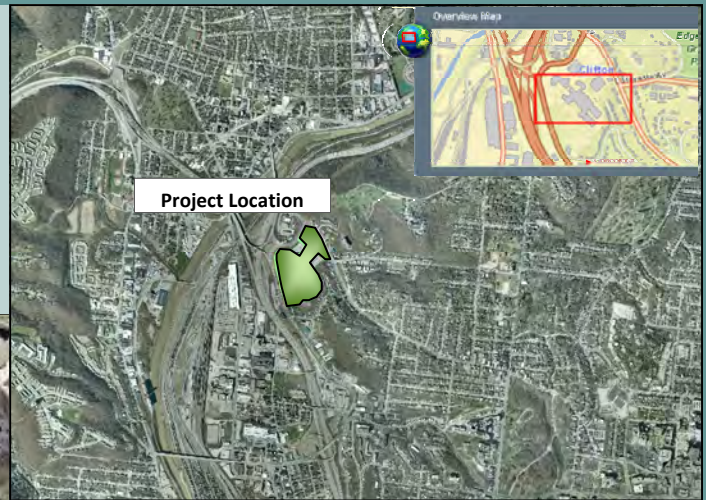

**GREEN INFRASTRUCTURE FEATURES**

**Porous/Permeable Pavements**

Porous/permeable paving with underdrains, including 2,002 square feet of porous asphalt, 1,645 square feet of porous concrete and 40,038 square feet of permeable pavers, were installed at various locations.

**Rain Gardens**

Ten rain gardens totaling 56,222 square feet were installed in various locations to detain and infiltrate runoff. Two different underdrain configurations were utilized, with and without geotextile filter fabric.

**Rainwater Harvesting**

Two 10,000 gallon underground tanks connected to irrigation systems and one 4,000 gallon above ground tank for use at the greenhouse were installed.

**Level Spreader**

A terraced 420 square foot level spreader system to detain and infiltrate runoff was installed.

**Living Wall**

A 140 foot long living wall planted with sedum also functions as retaining wall for rain garden.

**Subsurface Infiltration Trenches**

A StormTech® sub-surface infiltration chamber was installed to detain and infiltrate runoff below the ground surface.

**Basin Retrofit**

Existing basin retrofitted to detain and infiltrate runoff.

**MSD FUNDING**

Design: \$188,280

Construction: \$1,998,194

Education and Signage: \$48,000

MSD funding comprised 69% of the total construction costs<sup>2</sup>.

**PROJECT BENEFIT**

The estimated total annual volume of runoff removed in a typical year is approximately 12.6 million gallons. The estimated construction cost<sup>2</sup> per captured gallon is \$0.16.

**LEGEND**

- Pervious Pavers
- Porous Asphalt
- Living Wall
- Basin Retrofit
- Level Spreader
- Porous Concrete
- Rain Garden
- Rainwater Harvesting
- Subsurface Infiltration Trenches
- Treatment Train Connectivity

<sup>1</sup>The typical year used in this estimate assumes total annual rainfall of 41 inches.

<sup>2</sup>Construction costs are approximate pending receipt of all invoices.

## ENABLED IMPACT PROJECT UPDATE

### PROJECT: CINCINNATI STATE CAMPUS

PROJECT PARTNER: CINCINNATI STATE TECHNICAL AND COMMUNITY COLLEGE



#### MONITORING

MSD partnered with USEPA to install monitoring equipment in various BMPs at Cincinnati State. Water content reflectometers and temperature sensors were installed in two large permeable paver cells (shown in photo at left). EPA is also installing monitoring equipment to track the performance of the underground infiltration chambers, and the rainwater harvesting systems. The performance data will be shared with MSD and Cincinnati State.

Dr. Robert Pitt from the University of Alabama has produced a monitoring plan which includes the level spreader, bioretention cells, and some of the rain gardens.

Seasonal site inspections will be conducted quarterly to assess long-term viability of the green controls and to identify potential operation and maintenance issues. Site visits will also be conducted after high intensity wet weather events to assess performance of the controls and, where appropriate, overflow structures.

### Design Plan Lot C Improvements: Porous Asphalt, Porous Concrete, Permeable Pavers, Cistern, Basin Retrofit, and Rain Gardens

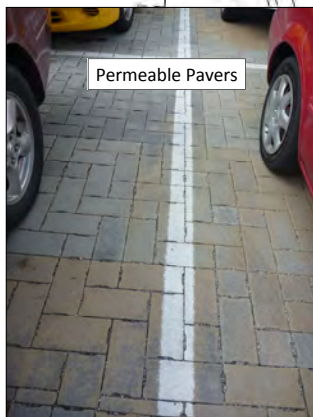

Permeable Pavers



Porous Asphalt



Basin Retrofit



Rain Garden



**ENABLED IMPACT PROJECT UPDATE**

**PROJECT: CINCINNATI STATE CAMPUS**

PROJECT PARTNER: CINCINNATI STATE TECHNICAL AND COMMUNITY COLLEGE



Design Plan showing 6 Rain Gardens, StormTech® Sub-surface Infiltration Chamber, Living Wall, Level Spreader and Permeable Pavers

# ENABLED IMPACT PROJECT UPDATE

## PROJECT: CINCINNATI STATE CAMPUS

PROJECT PARTNER: CINCINNATI STATE TECHNICAL AND COMMUNITY COLLEGE



### Infiltration Trench Detail

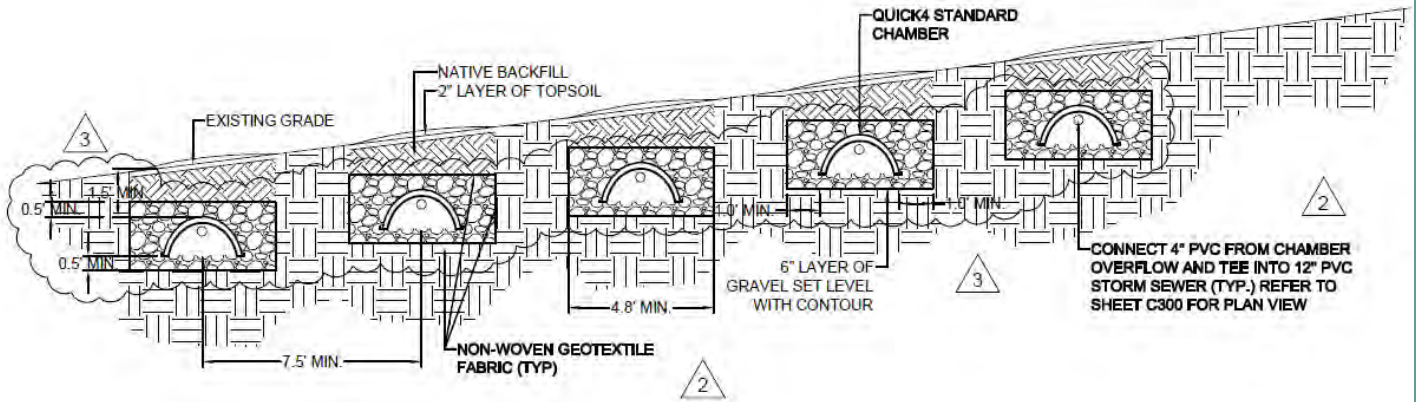

### Level Spreader Details

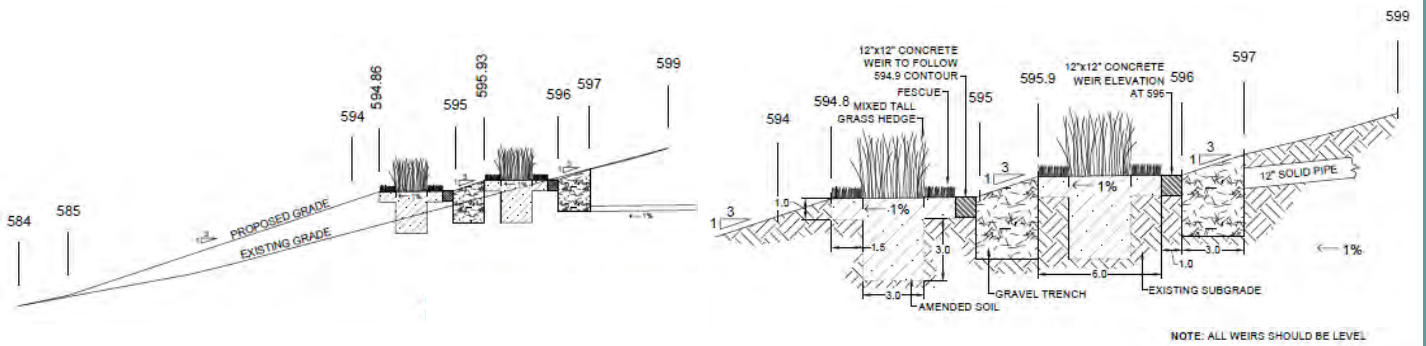

### Rain Garden and Permeable Pavement Detail

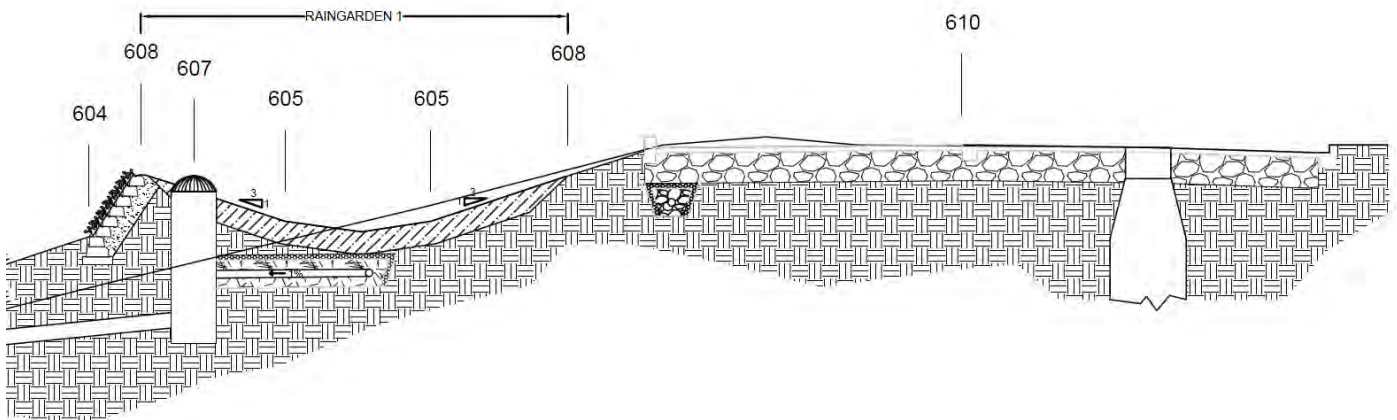

For more information about Project Groundwork, the Enabled Impact Program, or this project please email MaryLynn Lodor, Environmental Programs Manager at: [MaryLynn.Lodor@cincinnati-oh.gov](mailto:MaryLynn.Lodor@cincinnati-oh.gov).

## **ENABLED IMPACT PROJECT UPDATE**

### **PROJECT: CINCINNATI STATE CAMPUS**

**PROJECT PARTNER: CINCINNATI STATE TECHNICAL AND COMMUNITY COLLEGE**



***Lesson Learned: Forebay designs should allow for proper drainage to prevent stagnation and mosquito breeding conditions.***

The inlets into the bioinfiltration basins were designed with low entry elevations and a clay berm surrounding the inlet to the basin to create a sediment forebay. This design did not allow stormwater to drain out of the forebay section, and the ponding has caused stagnation and mosquito breeding in this area. Bioinfiltration basins, including forebay features, should be designed to fully drain within 48 hours of the rain event.



Water ponded in this forebay caused stagnation and conditions amenable for mosquito breeding.

***Lesson Learned: Measures should be taken to prevent excess sediment from clogging the green features during construction.***

Raw materials were stored adjacent to the proposed porous pavement areas, which allowed unnecessary, excess sediment to build up in the gravel sub base and pavement voids. Additionally, dirty construction equipment was parked on the newly installed porous pavements and excavated material was placed on the newly installed porous pavements. Future projects should not allow raw materials to be stockpiled near any green stormwater management features and should require extra precautions to prevent excess sediment from clogging the green stormwater management features.



Stock piled raw materials adjacent to the porous pavement areas under construction, vehicles parked on features.



Excess silt and sediment on the porous pavement surface can prematurely clog the system.

***Lesson: Outlet control structures should be placed so topsoil cannot easily wash into the outlet control structure.***

The location and elevation of an outlet control structure should minimize the likelihood of the topsoil and amended soil washing out of the basin and into the sewer system.



Topsoil can easily wash into this outlet control structure.

## ENABLED IMPACT PROJECT UPDATE

### PROJECT: CINCINNATI STATE CAMPUS

PROJECT PARTNER: CINCINNATI STATE TECHNICAL AND COMMUNITY COLLEGE



***Lesson Learned: The installation of porous pavers is more efficient with a mechanical paver installation machine.***

Many people associate pavers with extensive labor and hand work, but large areas can be paved very quickly and efficiently with a mechanical paver installation machine.



Mechanical paver installation machine provides quick installations of large porous paver systems.

***Lesson learned: Pea gravel between pavers will settle over time resulting in the need for placing pea gravel.***

Since the pea gravel fill placed between porous pavers will settle over time, the contractor may need to return after settling to place additional gravel in the paver voids.



The pea gravel in this system has settled.

***Lesson Learned: Porous pavement is not ideal for heavy traffic areas.***

Porous paving located in heavy traffic areas is susceptible to rutting. Some porous pavers have been damaged by heavy trucks. Analysis of the traffic patterns and use of an area should be completed before porous pavement is installed on site. Additionally, paver manufacturers should be consulted about compaction specifications.



Rutted porous pavers from heavy traffic.

***Lesson Learned: A silt fence should be installed around the green feature as material is placed.***

If a rain event occurs while the amended soil or gravel is being placed in a green feature and a silt fence has not been installed around the green feature, native and exposed materials on the construction site will wash into the open green feature clogging the amended soil or gravel with silt and sediment. Installing and maintaining a silt fence around the green feature before material is placed is recommended. This is critical to the performance of the green feature. Ultimately, the top eight to ten inches of accumulated sediment was removed prior to completing the installation.



After a rain event, stormwater ponded and sediment built up on top of the bioinfiltration basin's amended soil.

***Lesson Learned: Heavy equipment should not be driven on the green feature during installation to prevent compaction of the material and reduced infiltration rates.***

Maximizing infiltration rates of the native soil is crucial to the success of installed green features. When heavy equipment is driven over the surface, the underlying soil is compacted and infiltration capabilities can be significantly reduced. Soil here was scarified prior to installation of the remaining components of the green feature.



Heavy construction equipment compacts the native soil

## ENABLED IMPACT PROJECT UPDATE

### PROJECT: CINCINNATI STATE CAMPUS

PROJECT PARTNER: CINCINNATI STATE TECHNICAL AND COMMUNITY COLLEGE



***Lesson Learned: Maintenance of erosion protection and sediment control measures is critical to the success of the green feature installation.***

Exposed soil is more susceptible to erosion; and therefore, when vegetation is removed during construction, proper measures for erosion protection and sediment control should be taken. This is particularly important during construction of green features which can be easily clogged if silt and sediment wash into the proposed system.



Broken silt fence promotes erosion and sediment build up in the proposed green feature.

***Lesson Learned: To avoid foreign material from entering the green feature, understand the upstream storm network and drainage area.***

When retrofitting an existing detention basin feature, it is important to understand what drains to existing pipes and the condition of these pipes. In some cases, unknown pipes can bring foreign material into the green feature causing challenges during construction and additional maintenance needs. Here the pipe was jetted before project completion.



Debris and foreign material from an existing pipe draining into a retrofitted detention basin.

***Lesson Learned: Porous asphalt functions best once the pavement surface is wetted.***

At Cincinnati State, a test was performed by pouring water directly onto dry, porous asphalt pavement and some of the water appeared to runoff across the surface. Porous asphalt must be wetted before water will readily infiltrate into the pavement because the surface tension of dry, porous asphalt does not allow the water to infiltrate until it has been fully wetted.



Water does not infiltrate as readily on dry, porous asphalt.

***Lesson Learned: Underdrains should be designed to minimize the probability of clogging.***

Studies have shown that even a small amount of silt can cause filter fabric around an underdrain to clog. Underdrains should be designed to minimize the probability of clogging. The contractor must take extra precautions to prevent clogging prior to and during installation.



Filter fabric and an underdrain being installed.

## ENABLED IMPACT PROJECT UPDATE

### PROJECT: CINCINNATI ZOO AFRICAN SAVANNAH

PROJECT PARTNER: CINCINNATI ZOO AND BOTANICAL GARDEN

PROJECT STATUS: Completed

CSO BASIN(S): NO. 482

WATERSHED: South Branch Mill Creek



#### PROJECT LOCATION

The Cincinnati Zoo and Botanical Garden is located at the northeast corner of Vine Street and Erkenbrecher Avenue. The project site is located on the east side of the Zoo along Dury Avenue.

#### SITE DESCRIPTION

##### Project size/setting:

The existing site is 5.46 acres and is comprised of a large parking lot, open spaces and steep wooded hillsides. It is located in an urban residential area.

##### Drainage area to green infrastructure:

17.2 acres



#### GREEN INFRASTRUCTURE FEATURES

The African Savannah project has large areas of enhanced turf/vegetation, storm sewer separation and redirection of rooftop and surface runoff into a rainwater storage and reuse system. It is the Zoo's goal to generate zero site runoff during a 50-year storm event.

##### Enhanced Turf/Vegetation System

The existing 4-acre asphalt parking lot will be replaced with turf grass and other vegetation and new African Savannah exhibit space.

##### Storm Sewer Separation and Roof Leader Collection

The existing storm sewer and roof leader system in the project area discharges directly into the combined sewer. This project separates the existing storm sewer system and roof leader system from the combined sewer and redirects runoff into an underground storage system through installation of a new storm sewer network approximately 2,000 linear feet in total length.

##### Runoff Storage System and Rainwater Harvesting

The proposed stormwater collection system diverts runoff into a StormTech® storage system. Total storage volume for the system is 15,975 cubic feet. Stored runoff will be used for irrigation on the project site. A small pump station will convey runoff, filtered water from the storage facility to replenish the Bear Moat and Swan Lake.

#### MSD FUNDING

Comprises 6% of the total African Savannah project budget.

Design: \$20,000

Construction: \$1,297,676.30<sup>1</sup>

Monitoring: \$5,500

Education and Signage: \$10,000

#### PROJECT BENEFIT

Annual stormwater reduction into the combined system is estimated at 15.6 million gallons<sup>2</sup> with a cost per gallon of \$0.08.

#### MONITORING

Seasonal and wet weather site inspections will be conducted quarterly to assess long-term viability of the green controls and to identify potential operation and maintenance issues. USGS is currently monitoring groundwater. MSD is monitoring flow from the site. A monitoring plan for key controls is under development.

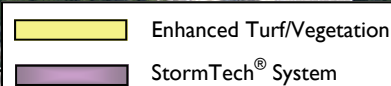
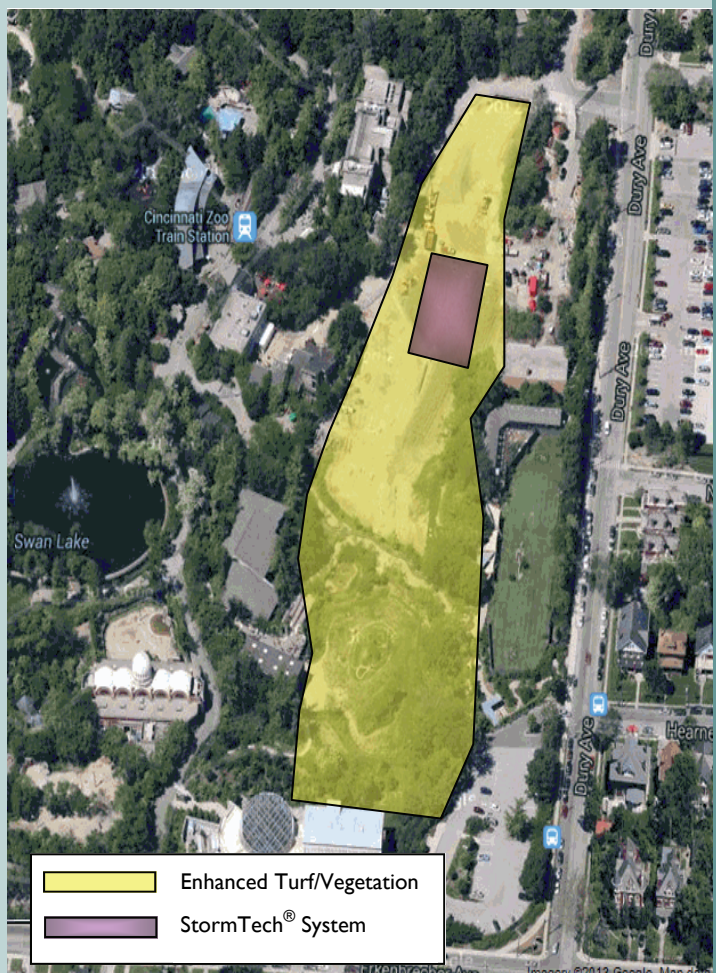

<sup>1</sup>Construction costs are approximate pending receipt of all invoices. <sup>2</sup>The typical year used in this estimate assumes total annual rainfall of 41 inches.

**ENABLED IMPACT PROJECT UPDATE**

**PROJECT: CINCINNATI ZOO AFRICAN SAVANNAH**

**PROJECT PARTNER: CINCINNATI ZOO AND BOTANICAL GARDEN**



**StormTech® Rainwater Harvesting and Storage System Plan**

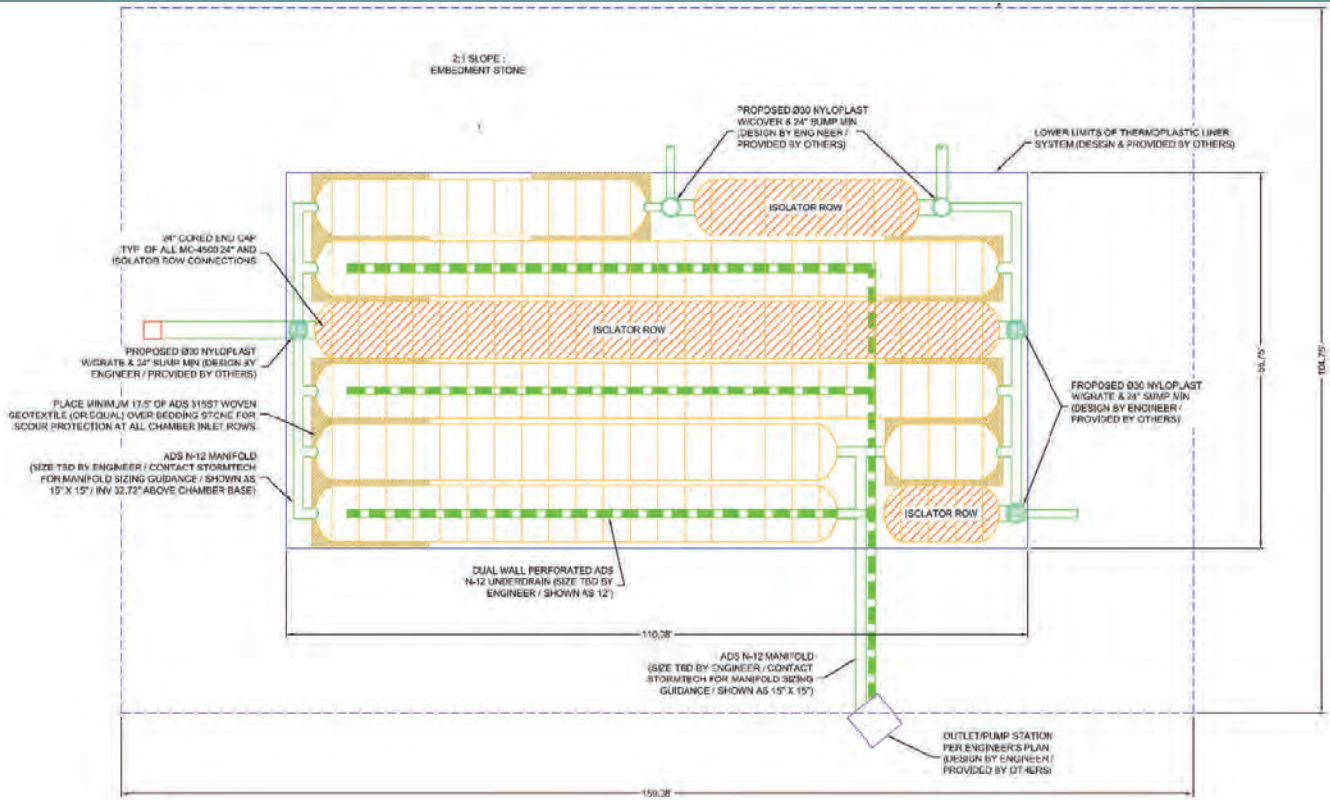

**StormTech® Storage System Profile**

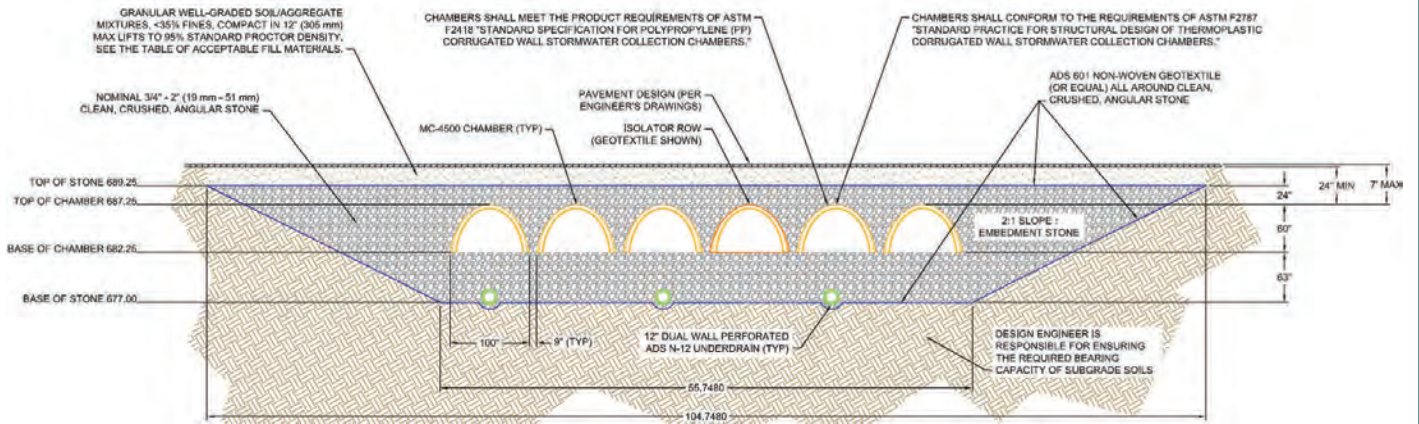

For more information about Project Groundwork, the Enabled Impact Program, or this project please email MaryLynn Lodor, Environmental Programs Manager at: [MaryLynn.Lodor@cincinnati-oh.gov](mailto:MaryLynn.Lodor@cincinnati-oh.gov).

## ENABLED IMPACT PROJECT UPDATE

### PROJECT: ZOO MAIN ENTRY

PROJECT PARTNER: CINCINNATI ZOO & BOTANICAL GARDEN

PROJECT STATUS: Complete

CSO BASIN(S): No. 482

WATERSHED: Mitchell Avenue/Mill Creek



#### PROJECT LOCATION

Located in Avondale, north of downtown Cincinnati, Ohio, the site is bounded by Vine Street and Erkenbrecher Avenue on the east and south.

#### SITE DESCRIPTION

**Project size/setting:** The site area is 2.3 acres with a disturbed area of 1.9 acres. The project is in an urban institutional/park setting.

**Drainage area to green infrastructure:**

188,179 square feet of rooftop and surface runoff.

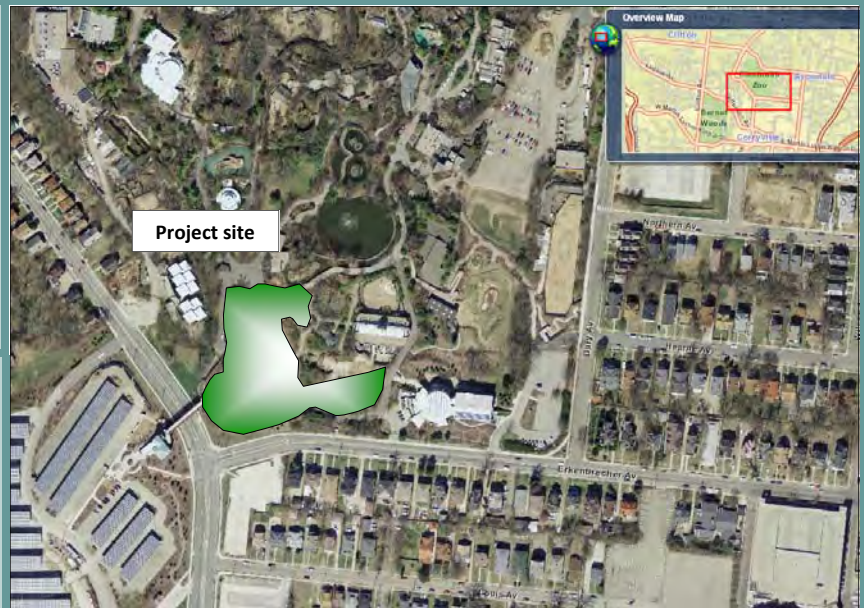

#### GREEN INFRASTRUCTURE FEATURES

Creation of a new Main Entry in 2010 provided an opportunity to incorporate many green stormwater controls. The Zoo's performance goal for these features is zero stormwater discharge.

##### Pervious Pavers

The Zoo installed 30,760 square feet of interlocking pervious pavers. The pervious paver system includes a 27-inch thick layer of #57 aggregate to be used for storage and infiltration purposes. This is underlain by a layer of filter fabric. Due to the relatively high percolation rates, an underdrain system at this location was not necessary.

##### Rainwater Harvesting and Reuse

A rainwater harvesting and reuse system includes a 10,000 gallon rainwater storage tank collects runoff from 11,700 square feet of rooftop. The tank includes a pump to allow use of the captured runoff for irrigation of landscaped areas.

##### Elephant Moat Storage and Infiltration

Rainwater from a roughly 53,000 square foot area will be conveyed to an existing elephant moat via a 12-inch pipe. Modification of an outlet structure allows detention of the 100-year rain event.

##### Green Garden Demonstration Area

A Green Garden Educational Center contains small scale versions of sustainable practices including pervious concrete, a rain garden and a rain barrel.

#### MSD FUNDING

Comprises 1.6% of the total project construction cost.

Design: \$15,000

Construction: \$231,325

Monitoring: \$3,207

Education and Signage: \$ 20,450

#### PROJECT BENEFIT

The stormwater management goal of the project was to have zero discharge to combined sewer. Estimated annual volume of captured runoff is 1.11 million gallons in a typical year<sup>1</sup> making the construction cost per captured gallon \$0.24.

#### MONITORING

A flow meter to measure runoff leaving the Zoo has been in place since 2009 at stormwater manhole number 338162022. Four shallow wells for measuring water levels were installed in the pervious paver areas (the Zoo purchased water measuring instruments). An onsite weather station collects rainfall and related data to correlate with monitoring efforts. Seasonal site inspections will assess performance, and operation and maintenance needs.



<sup>1</sup>The typical year used in this estimate assumes total annual rainfall of 41 inches.



**ENABLED IMPACT PROJECT UPDATE**

**PROJECT: ZOO MAIN ENTRY**

**PROJECT PARTNER: CINCINNATI ZOO AND BOTANICAL GARDEN**



**Main Entry Demonstration Project Plan and Installed Green Infrastructure**

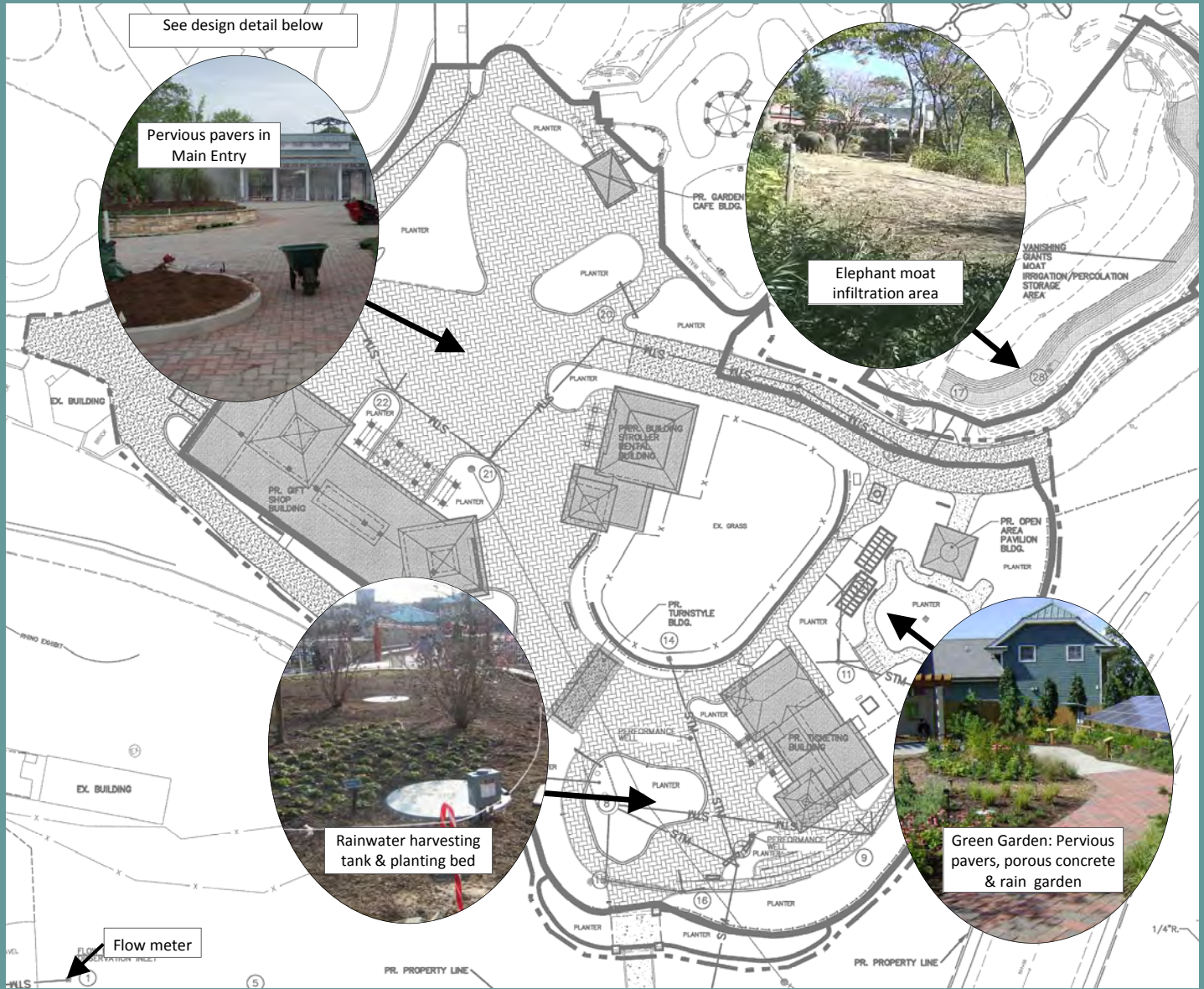

**Pervious Paver Design Schematic and Installation**

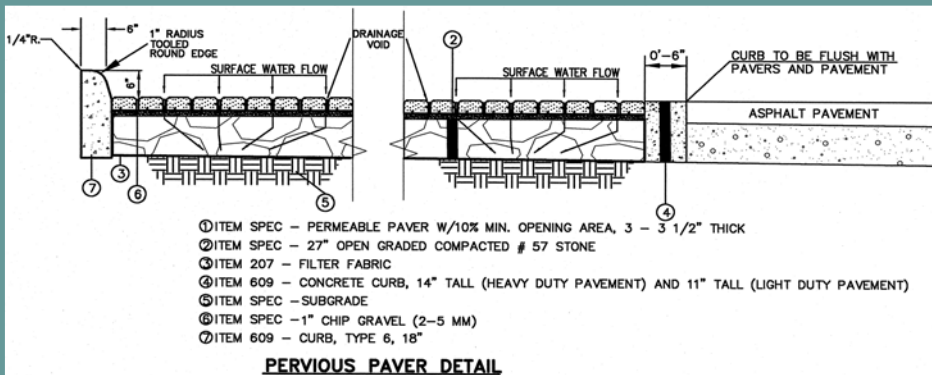

For more information about Project Groundwork, the Enabled Impact Program, or this project please email MaryLynn Lodor, Environmental Programs Manager at: [MaryLynn.Lodor@cincinnati-oh.gov](mailto:MaryLynn.Lodor@cincinnati-oh.gov).

## **ENABLED IMPACT PROJECT UPDATE**

### **PROJECT: ZOO MAIN ENTRY**

**PROJECT PARTNER: CINCINNATI ZOO AND BOTANICAL GARDEN**



#### ***Lesson Learned: Install a barrier between mulched planting beds and porous pavers.***

When sloped, mulched planting beds are adjacent to porous pavers, a barrier should be installed on the edge of the mulched planting bed to help prevent the mulch and soil from running off and spreading over the porous pavers. This sediment builds up in the porous paver system and prevents infiltration. The Zoo vacuumed the affected areas to remove accumulated materials. A concrete curb keeps mulch in place in planted area at right.



Sediment built up in the porous paver system.



Sloped, mulched planting bed upstream of porous pavers.

## ENABLED IMPACT PROJECT FACT SHEET

### PROJECT: GREEN LEARNING STATION

PROJECT PARTNER: CIVIC GARDEN CENTER

PROJECT STATUS: Complete

CSO BASIN(S): No. 461

WATERSHED: South Branch Mill Creek



#### PROJECT LOCATION

Located just north of downtown Cincinnati, Ohio in the Avondale neighborhood, the site is on southwest corner of Reading Road and Oak Street.

#### SITE DESCRIPTION

**Project size/setting:** The site is located in an urban commercial/urban residential area and was a former gas station.

**Drainage area to green infrastructure:** All stormwater runoff from this site is managed by green stormwater controls. The total drainage area is approximately 0.45 acres.



#### GREEN INFRASTRUCTURE FEATURES

The Green Learning Station Project is intended to educate visitors on the importance of green infrastructure, the functions of each green feature, and how similar applications can be implemented in residential and commercial settings.

##### Rainwater Harvesting

Runoff from the Green Learning Station building roof is discharged into a 3,000 gallon above-ground cistern. Collected runoff is used for irrigation of various plantings on site.

##### Pervious Parking

Five 1,200-square foot parking bays utilize four different pervious pavement parking surfaces. These surfaces are permeable pavers, porous asphalt, porous concrete and an impervious concrete control section. A control parking bay is topped with standard concrete.

Each parking bay is separated by a five inch wide concrete curb and an impervious liner. A perforated underdrain installed in each bay conveys excess runoff to a central pump station and pumped to the adjacent bioswale for irrigation. Incoming and outgoing flows from the paver areas and the pump station can be measured.

##### Bioswales

Two bioswales were constructed along Reading Road using two different soil media mixes which will be used for researching the impact of soil media on the overall functionality. A third bioswale is located next to Oak Street. The total area of the three bioswales is approximately 1,502 square feet.

##### MSD FUNDING

Design: \$30,000

Construction: \$319,736

Monitoring Equipment/Weather Station: \$84,240

Signage and Educational Material: \$26,100

MSD funding comprises 24% of the total construction budget.

##### PROJECT BENEFITS

MSD funding for this project is primarily for the research and data that will be generated from the extensive monitoring system that has been installed. There are also numerous educational components for the general public. The estimated

annual volume of captured runoff is 40,000 gallons in a typical year<sup>1</sup> with a construction cost per captured gallon of \$7.99.

##### MONITORING

Each green control was designed to be self contained and contains numerous sensors and devices to measure flow and related parameters. A fully automated monitoring system provides real time monitoring capabilities to measure water diffusion through surfaces, vegetative evaporation rates, and flow into the combined sewer system. It also monitors the porous concrete/asphalt, pervious pavers, and conventional concrete areas separately in order to determine the effectiveness of each surface. Water level sensors are installed to determine storage in 11 areas throughout the site. A rain gauge and weather station provides precipitation and weather data which is used to evaluate system effectiveness.



<sup>1</sup>The typical year used in this estimate assumes total annual rainfall of 41 inches.

**ENABLED IMPACT PROJECT UPDATE**  
**PROJECT: GREEN LEARNING STATION**  
**PROJECT PARTNER: CIVIC GARDEN CENTER**



**Civic Garden Center Design Plan and Green Infrastructure Photos**



Rainwater Harvesting



Shallow Vegetative Roof



Vegetative Roof Trays

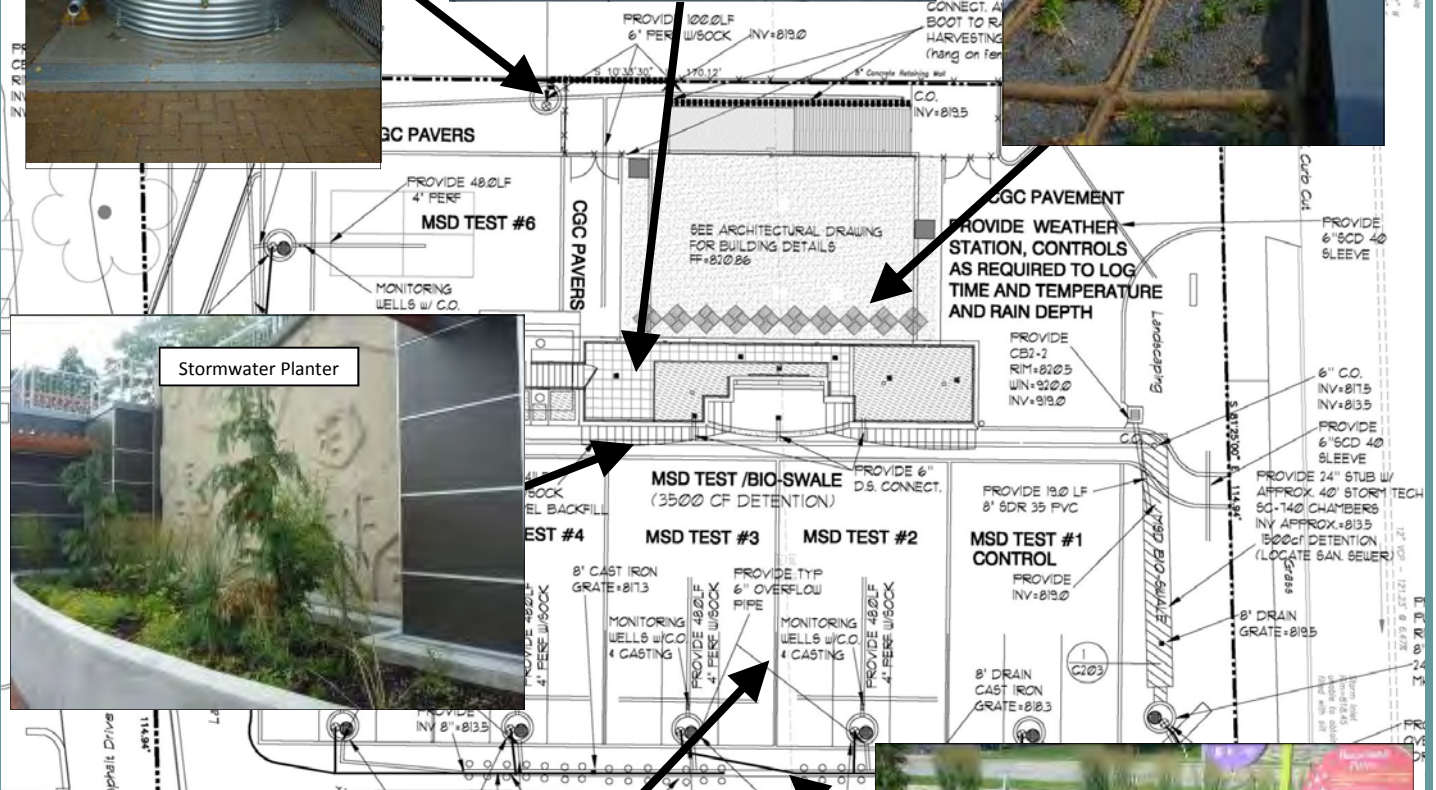

Stormwater Planter

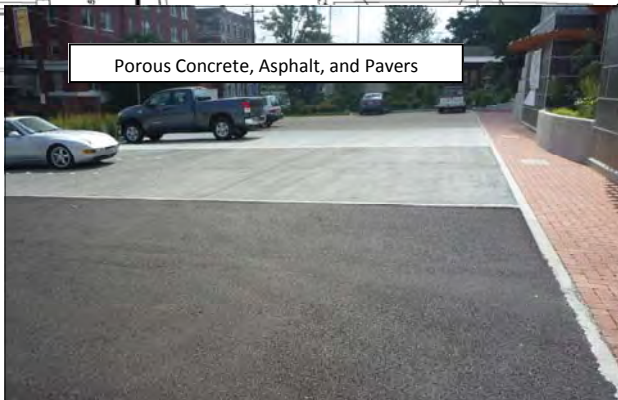

Porous Concrete, Asphalt, and Pavers



Bioswale

For more information about Project Groundwork, the Enabled Impact Program, or this project please email MaryLynn Lodor, Environmental Programs Manager at: [MaryLynn.Lodor@cincinnati-oh.gov](mailto:MaryLynn.Lodor@cincinnati-oh.gov).

## **ENABLED IMPACT PROJECT UPDATE**

### **PROJECT: GREEN LEARNING STATION**

**PROJECT PARTNER: CIVIC GARDEN CENTER**



#### ***Lesson Learned: Innovative designs may generate new issues.***

This design includes several green features linked in series to allow stormwater draining from the five porous pavement systems to be pumped directly into a perforated pipe located in the amended soil layer of the bioswales. This was intended to permit saturation of the amended soil to enhance vegetative success in the bioswales. However, sand in the amended soil is blowing of the system above the top soil layers. (See photos) It appears that the system pumps are too strong resulting in the blowouts. Fortunately, flow in the pumps can be regulated. Also, the perforated pipe is to be wrapped in another material to diffuse outward flow strength.



Sand washed out of the amended soil above the topsoil.



Bioswale overview illustrating sand washout onto adjacent wall.

## ENABLED IMPACT PROJECT UPDATE

### PROJECT: CLARK MONTESSORI HIGH SCHOOL

PROJECT PARTNER: CINCINNATI PUBLIC SCHOOLS

PROJECT STATUS: Complete

CSO BASIN(S): NO. 469

WATERSHED: Duck Creek



PROJECT GROUNDWORK  
your pipeline to clean water

#### PROJECT LOCATION

The project is located on Erie Street, east of downtown Hyde Park in Cincinnati, Ohio

#### SITE DESCRIPTION

**Project size/setting:** The project area is 11 acres, of which 67% is estimated to be impervious surfaces. The school is located in an urban-residential setting and is a re-build of an existing school.

**Drainage area to green infrastructure:** The drainage area is approximately 98,900 square feet.

#### GREEN INFRASTRUCTURE FEATURES

Construction of a new school presented an opportunity to incorporate multiple green stormwater controls. The local community is also very supportive of environmental projects.

##### Vegetative Roofs

Two vegetative roofs were installed at Clark: 9,200 sq. ft. of intensive roof and 5,500 sq. ft. of extensive roof. Both are layered rather than tray systems. The intensive roof, which can be accessed on foot from an adjacent hillside, includes a permanent sub-surface irrigation system.

##### Pervious Pavements

Two types of pervious pavements were installed, including 13,000 square feet of porous concrete and 2,000 square feet of permeable pavers. There are no underdrains beneath these items.

##### Bioretention Facilities

Two bioswales, three stormwater planters, and one rain garden were installed on the school grounds. None of these features were installed with underdrains due to sandy soils encountered during construction.

##### MSD FUNDING

Design: \$68,115

Construction<sup>2</sup>: \$714,469

The MSD-funded share for construction of the green stormwater control for this project represents 7% of the total CPS construction cost<sup>2</sup>.

##### PROJECT BENEFIT

The project demonstrates the use of green controls in an urbanized educational institution setting. The features are highly visible to students, staff, and visitors to the school. The estimated annual volume of captured runoff is up to 1,875,000 gallons based on the typical year<sup>1</sup>. The estimated construction cost per captured gallon is \$0.39.

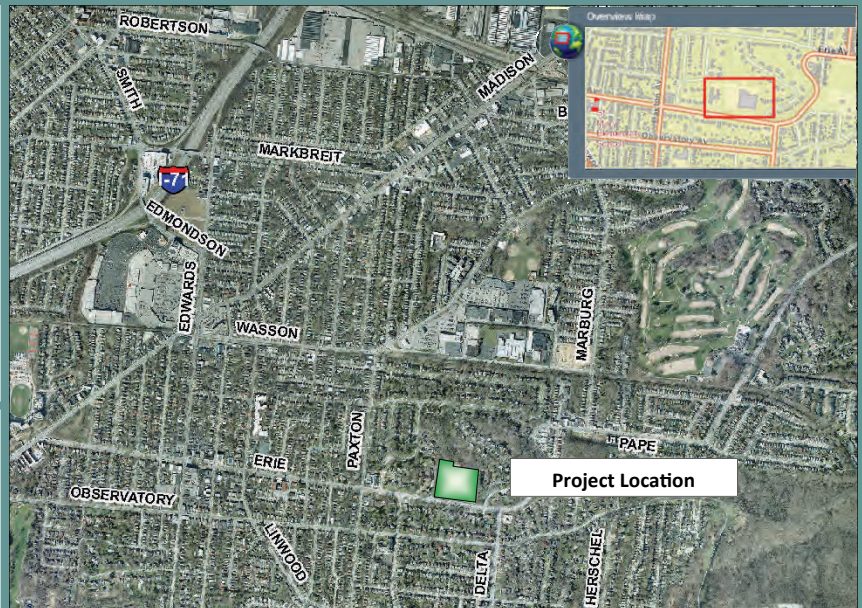

#### MONITORING

MSD partnered with USEPA to install monitoring equipment in various BMPs. In the northwest parking lot, EPA installed water content and temperature sensors in the porous concrete as well as installed monitoring equipment in the bioswale to measure water content. The EPA performance data will be shared with MSD following numerical analysis. Seasonal site inspections will be conducted quarterly to assess long-term viability of the green controls and to identify potential operation and maintenance issues. Site visit will also be conducted after high intensity wet weather events to assess performance of the controls and, where appropriate, overflow structures.

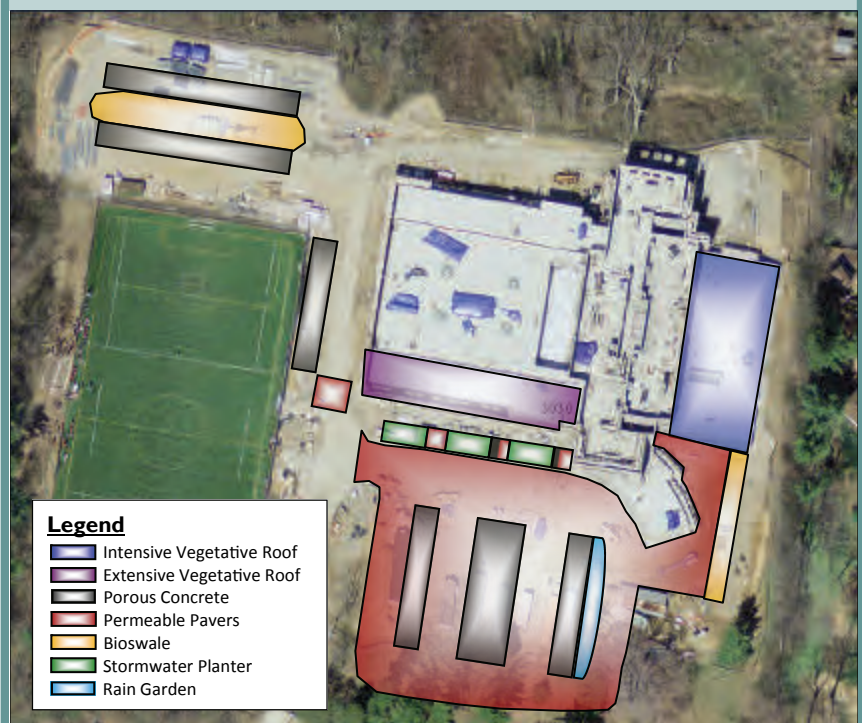

<sup>1</sup>The typical year used in this estimate assumes total annual rainfall of 41 inches. <sup>2</sup>Construction costs are approximate pending receipt of all invoices.

**ENABLED IMPACT PROJECT UPDATE**

**PROJECT: CLARK MONTESSORI HIGH SCHOOL**

**PROJECT PARTNER: CINCINNATI PUBLIC SCHOOLS**



**Clark Montessori Site Plan**

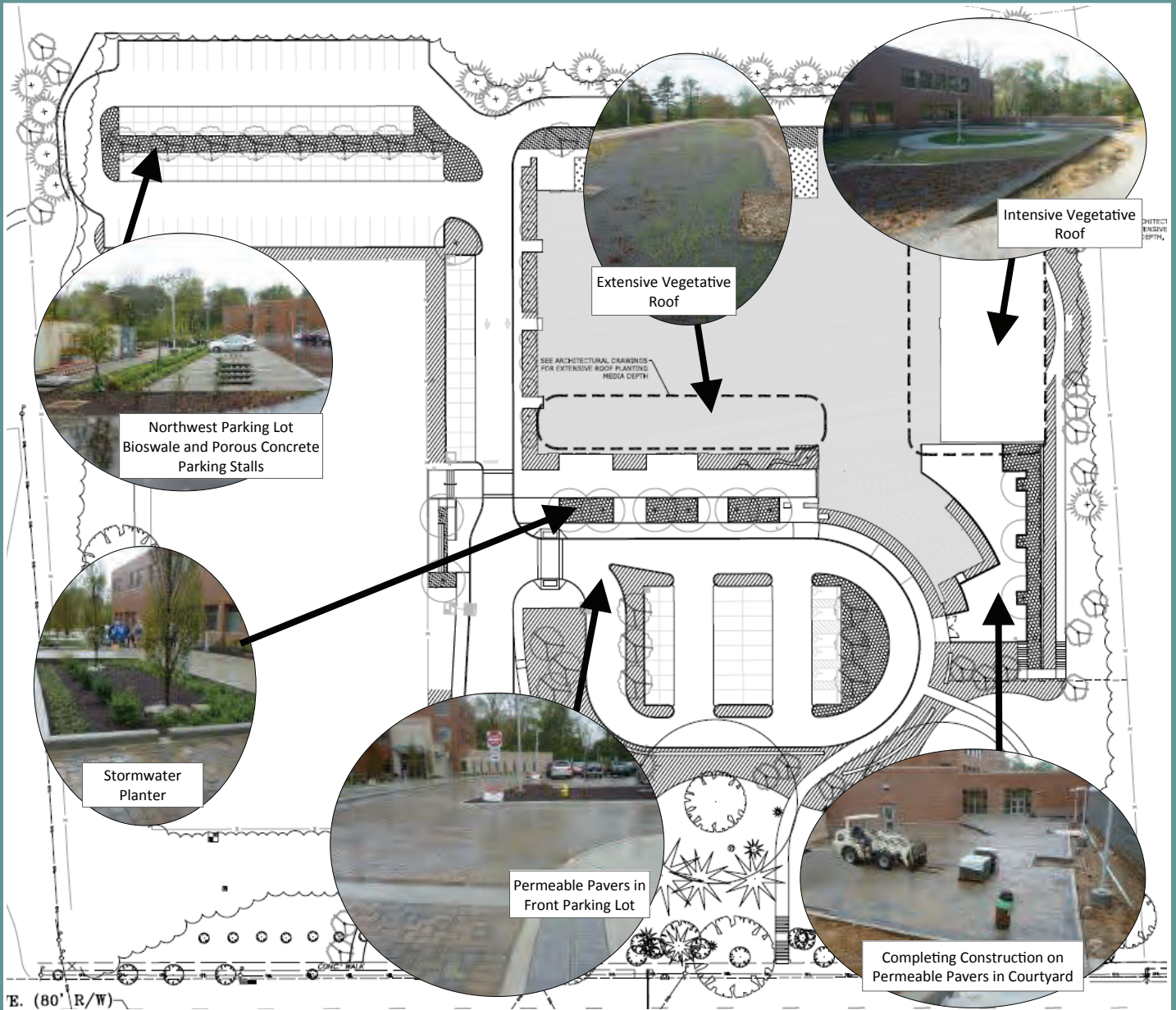

**Cross Section of Porous Concrete and Bioswale**

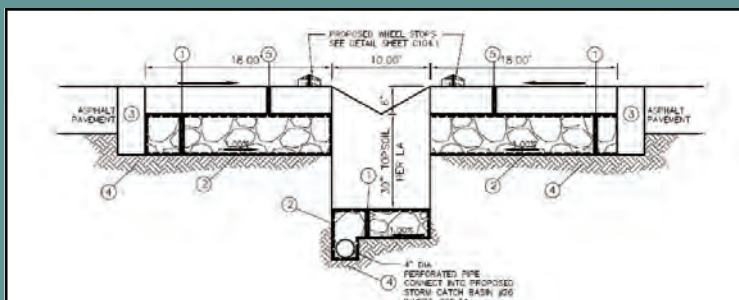

The porous concrete was poured without a permanent curb between the concrete and the bioswale. This was done to allow runoff to flow directly into the sub-surface of the bioswale after infiltrating through the porous concrete parking stalls. Wheel stops are used in place of a curb to stop cars from driving into the bioswale and compacting the soil. During construction, the perforated pipe was installed, but not connected to the downstream catch basin, as the soils were sandy enough for full infiltration of the runoff.

For more information about Project Groundwork, the Enabled Impact Program, or this project please email Lynn Lodor, Environmental Programs Manager at: [MaryLynn.Lodor@cincinnati-oh.gov](mailto:MaryLynn.Lodor@cincinnati-oh.gov) .

Mary-

## ENABLED IMPACT PROJECT UPDATE

### PROJECT: CLARK MONTESSORI HIGH SCHOOL

PROJECT PARTNER: CINCINNATI PUBLIC SCHOOLS



#### ***Lesson Learned: Vegetative roofs should be planted after all other roofing is complete.***

The intensive and extensive vegetative roofs were planted prior to much of the other work being performed in the vicinity of the vegetative roofs. Construction taking place adjacent to and on the vegetative roofs disturbed—and in some cases killed—the plants on the roofs. Once installed, plants on vegetative roofs should be cared for until they are fully established. In this case, however, care was handed over to the roofing company. The landscape company returned to the site to tend to the plants once construction was finished. All the plants that were disturbed or killed were eventually replaced. Maintenance of the plants is now



Uprooted plants on the vegetative roof.



Dead plants on the vegetative roof.

#### ***Lesson Learned: Soil testing is necessary to determine important design features needed to maximize the feasibility of green infrastructure.***

Soil testing was completed on site, but not in the exact location of the proposed green feature locations. During construction, sand seams were found on site, which indicated that infiltration rates may be high, and therefore, underdrains may not be necessary. This finding was not brought to the attention of the design engineer or landscape architect on the project until much of the construction had occurred. At that point, one underdrain had already been installed, and all the underdrains for the site had been ordered. Although no additional soil testing was completed, the decision was made to plug the underdrain that was already installed and to install all other green features on site without underdrains. In some cases the engineered soil had also been placed. The soil contained sand, as per the design. The sand would make the feature drain too rapidly—so the engineered soil was removed and replaced with a non-sand soil mixture. This additional effort and cost may not have been necessary.



Underdrain to be installed in the bioswale.



## **ENABLED IMPACT PROJECT UPDATE**

### **PROJECT: CLARK MONTESSORI HIGH SCHOOL**

**PROJECT PARTNER: CINCINNATI PUBLIC SCHOOLS**



***Lesson Learned: Construction equipment should not be driven on the green infrastructure during or after construction to avoid compaction and unnecessary clogging of the features.***

Sediment build up from mud on construction equipment was tracked over the gravel base of a pervious paver parking lot. Once the pavers were installed, this machinery continued to travel across the pavers with mud on the tires, causing the system to clog prematurely. In addition, the plastic was removed from the pervious concrete before finishing construction in the surrounding area, allowing excess silt and sediment to accumulate in the voids. The property owner will need to have the pavement area vacuumed to remove these materials.



Exposed dirt adjacent to the newly installed porous concrete can cause sediment build up and clog the system.



Exposed dirt adjacent to the newly installed porous paver system can cause sediment build up and clog the system.

***Lesson Learned: A barrier is necessary between a parking stalls and a green infrastructure.***

Parking blocks were not included in the design of this parking lot bioswale. Students and staff using the lot have accidentally driven their cars over the edge of the parking stalls, getting stuck in the bioswale and causing ruts in the amended soil. Parking blocks were placed prior to opening the parking lot to the general public. Bollards are to be installed at either end of the bioswale.



Tire ruts in the soil.



Tire ruts in the soil.

## ENABLED IMPACT PROJECT UPDATE

### PROJECT: HARTWELL ELEMENTARY

PROJECT PARTNER: CINCINNATI PUBLIC SCHOOLS

PROJECT STATUS: Complete

CSO BASIN: No. 171

WATERSHED: South Branch Mill Creek



#### PROJECT LOCATION

The project is located on the northeast corner of the intersection of Galbraith Road and Springfield Pike in the community of Hartwell. This community lies 10 miles north of downtown Cincinnati, Ohio.

#### SITE DESCRIPTION

**Project size/setting:** The project area is a roughly 4.94 acres, of which 57% is estimated to be impervious surfaces. The school is located in an urban residential/light commercial setting. The project area was previously a grassy field behind the school.

#### Drainage area to green infrastructure:

The drainage area for the porous concrete, estimated at 35,903 square feet, is primarily from the impervious portions of the asphalt parking lot.

#### GREEN INFRASTRUCTURE FEATURES

Planned renovation/new construction at the CPS Hartwell facility provided an opportunity to incorporate green stormwater controls on the site while it was undergoing a transformation. Site soils are moderately to highly permeable with measured infiltration rates of over 6 inches per hour, which is a desirable characteristic for green infrastructure. High permeability soils are rare in the Cincinnati area which is predominantly comprised of clay and silty clay near surface soils.

#### Porous Concrete

CPS installed porous concrete in 2010 in the parking lot to the west of the school building. It consists of an outer ring of impervious asphalt pavement with 47 inner parking stalls, totaling 8,072 square feet, which is constructed of porous concrete pavement.

The pervious pavement system consists of a 6-inch layer of porous concrete pavement and a 24-inch layer of aggregate base. Due to the permeable nature of the site soils, no underdrains were included in the design and installation of the porous concrete area.

#### MSD FUNDING

Design: \$26,200

Construction: \$15,500

The MSD funding for construction of the green stormwater control at this project was \$15,550 which was limited to the porous concrete surface only. The total cost for the porous concrete installation was \$35,806. MSD funding represented 43% of the porous concrete parking area cost and 0.14% of the total project cost.

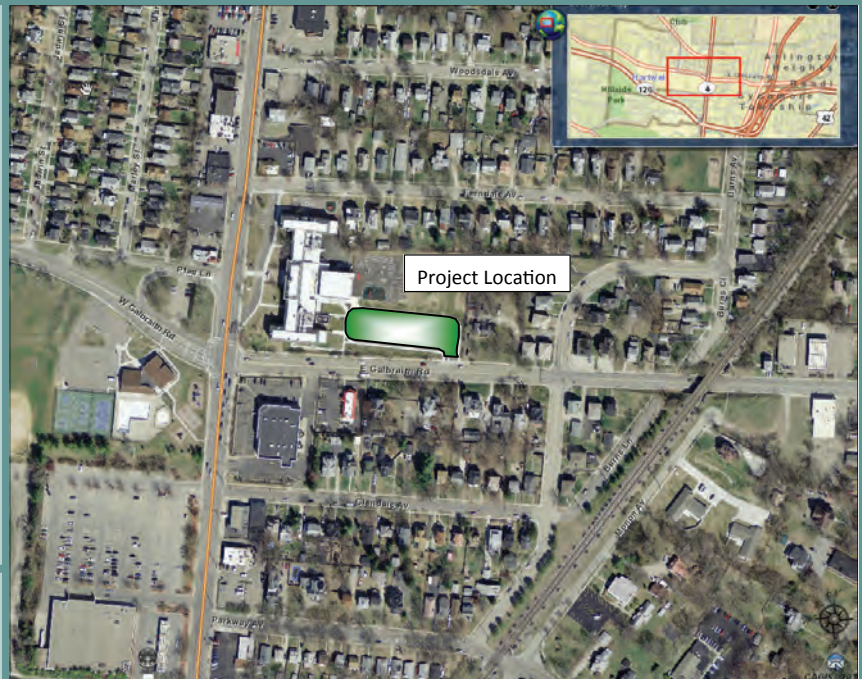

#### PROJECT BENEFIT

One of the goals of this project is to function as a demonstration of moderate to small scale green controls in an urban educational institution setting. The porous parking area is visible to many students, faculty, and guests that visit the school. The estimated annual volume of captured runoff is 614,000 gallons<sup>1</sup> with a construction cost per captured gallon of \$0.06.

#### MONITORING

The project is being monitored through a seasonal site inspection program where the facility is visited once a season to assess performance of the installed green stormwater controls and to identify any operation and maintenance needs.



<sup>1</sup>The typical year used in this estimate assumes total annual rainfall of 41 inches.

**Hartwell Elementary Demonstration Project Plan and Installed Green Infrastructure**

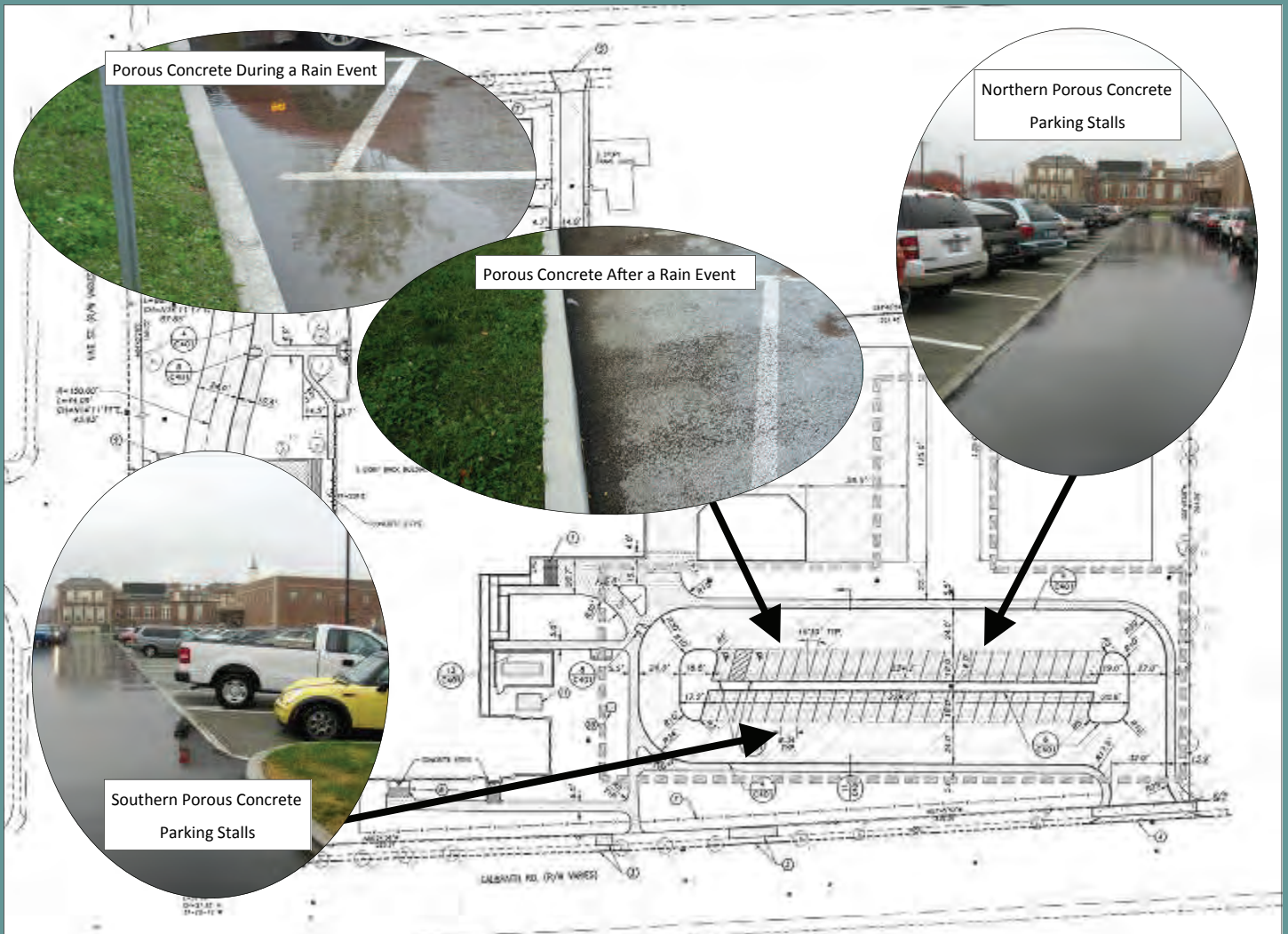

**Porous Concrete Cross Section**

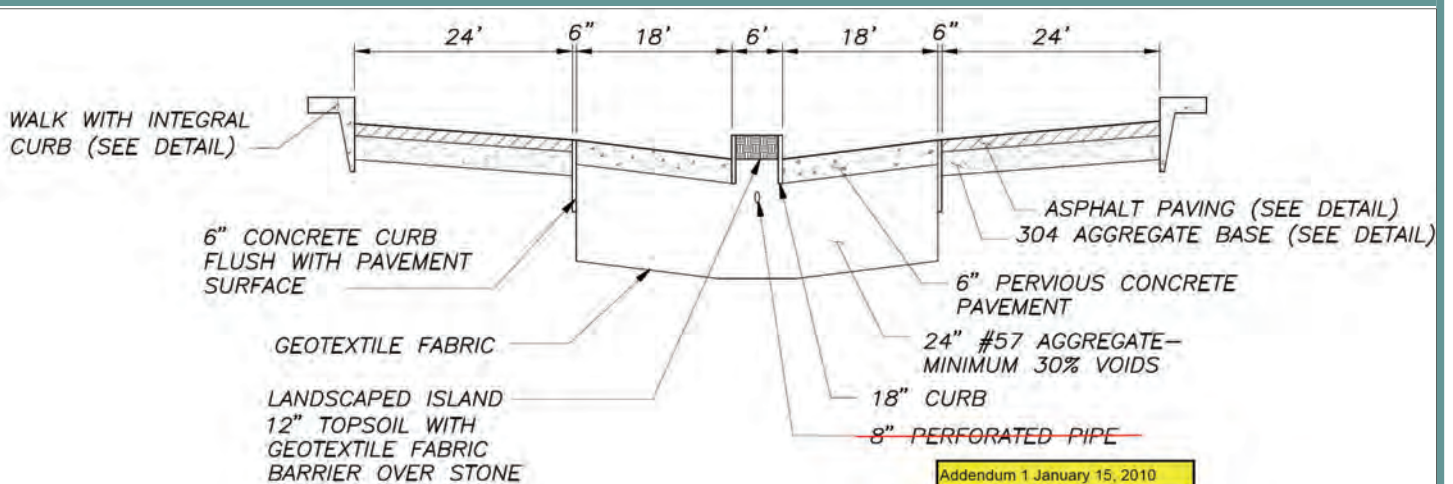

## **ENABLED IMPACT PROJECT UPDATE**

### **PROJECT: HARTWELL ELEMENTARY SCHOOL**

**PROJECT PARTNER: CINCINNATI PUBLIC SCHOOLS**



***Lesson Learned: When soils are favorable for stormwater infiltration, installation of additional green infrastructure should be encouraged.***

Despite geotechnical test results indicating the presence of sandy soils with high infiltration rates (greater than 6 inches per hour), only a small portion of the project site was designed to drain toward a green feature, pervious concrete parking stalls. In cases with soils favorable for stormwater infiltration, additional green infrastructure features should be encouraged to maximize the stormwater volume reduction benefit in these locations.



Porous concrete at Hartwell Elementary.

## ENABLED IMPACT PROJECT UPDATE

### PROJECT: NORTH AVONDALE MONTESSORI VEGETATIVE ROOF

PROJECT PARTNER: CINCINNATI PUBLIC SCHOOLS

PROJECT STATUS: Complete

CSO BASIN(S): No. 482

WATERSHED: Lower Mill Creek



#### PROJECT LOCATION

The project is located at 615 Clinton Springs Avenue, in the Avondale community north of downtown Cincinnati, Ohio.

#### SITE DESCRIPTION

**Project size/setting:** The project area is a 640 square foot section of rooftop located in the north-central portion of the facility. The setting is a new educational institution in an urban residential area.

#### Drainage area to green infrastructure:

The drainage area is equal to the size of the feature—640 square feet. None of the surrounding conventional roof system drains onto the vegetative roof.

#### GREEN INFRASTRUCTURE FEATURES

The planned construction of a new school at this site provided an opportunity to incorporate green stormwater controls. A 640 square foot extensive vegetative roof was constructed at this facility as part of the storm water management plan.

#### Vegetative Roof

Cincinnati Public Schools installed a 640 square foot, shallow vegetative roof system on a portion of the new school building in 2010. The vegetative roof consists of an assembly of 2-foot by 2-foot planting trays with a growing media depth of 4 inches. The roof is accessible via 2-foot by 2-foot walkway pads which lead from a stairway in the courtyard to a door into the school building. (See the reverse side of this fact sheet for the vegetative roof plans and project photographs.)

#### MSD FUNDING

Comprises 0.13% of the total renovation budget.

Design: \$9,800<sup>1</sup>

Construction: \$13,706

#### PROJECT BENEFIT

The project goal is to provide a demonstration of small scale vegetative roofs with education on a school campus as the primary function of the completed installation. This vegetative roof is also readily accessible and is used as an outdoor learning lab. The estimated annual volume of captured runoff is 10,000 gallons in a typical year<sup>2</sup> with a construction cost per captured gallon of \$2.35.

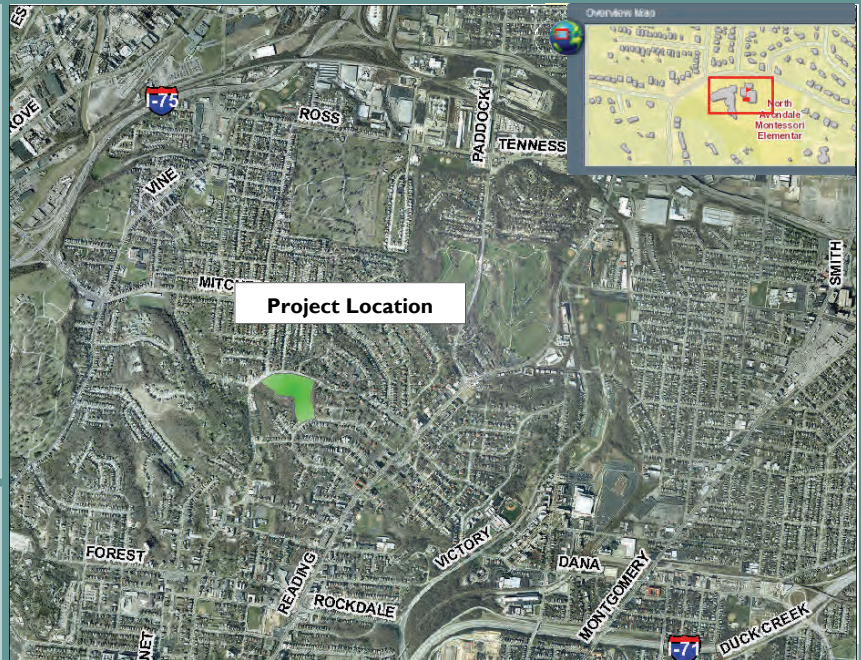

#### MONITORING

The project is being monitored through a site inspection program where the facility is visited annually to assess performance of the installed vegetated roof and to identify any operation and maintenance needs. Cincinnati Public Schools has expressed an interest in developing a monitoring program that can be run by students and staff.



<sup>1</sup>The original proposal included pervious paving in a courtyard, but the CPS construction schedule precluded it from being in the approved project.

<sup>2</sup>The typical year used in this estimate assumes total annual rainfall of 41 inches.

**ENABLED IMPACT PROJECT UPDATE**

**PROJECT: NORTH AVONDALE MONTESSORI VEGETATED ROOF**

**PROJECT PARTNER: CINCINNATI PUBLIC SCHOOLS**



**Extensive Vegetated Roof Plan and Installation Photos**



Vegetative roof area before and after installation.



Vegetative roof during a wet weather event in October 2011

For more information about Project Groundwork, the Enabled Impact Program, or this project please email  
MaryLynn.Lodor, Environmental Programs Manager at: [MaryLynn.Lodor@cincinnati-oh.gov](mailto:MaryLynn.Lodor@cincinnati-oh.gov) .

Mary-

## **ENABLED IMPACT PROJECT UPDATE**

### **PROJECT: TAFT IT HIGH SCHOOL**

**PROJECT PARTNER: CINCINNATI PUBLIC SCHOOLS**

**PROJECT STATUS: Complete**

**CSO BASIN(S): No. 431A**

**WATERSHED: Lower Mill Creek**



#### ***PROJECT LOCATION***

The project is located at Taft High School at 420 Ezzard Charles Drive in Cincinnati, Ohio.

#### ***SITE DESCRIPTION***

**Project size/setting:** The project area is 2.91 acres, of which 2.44 acres is impervious surfaces. The school is in a highly urbanized area with mixed residential and commercial development.

#### ***Drainage area to green infrastructure:***

The drainage area for the vegetative roof is 41,000 square feet—the size of the vegetative roof plus associated walkways. The estimated drainage area for the rain garden is 9,600 square feet.

#### ***GREEN INFRASTRUCTURE FEATURES***

The construction of a new school at this site provided an opportunity for installation of green stormwater controls, including the following:

##### **Vegetative Roof**

CPS installed 32,000 square feet of shallow vegetative roof system on the new high school in 2010. The vegetative roof consists of an assembly of two-foot by four-foot planting trays with a growing media depth of four inches. The trays were pre-planted with a variety of sedum and installed over protective fabric and an impermeable roof membrane. The roof includes walkways for access to rooftop equipment and vegetative roof features. A hose bib was installed for use during the plant establishment period.

##### **Rain Garden**

CPS installed one bioinfiltration basin at the north end of the building with a footprint of 1,070 square feet. The design consists of woody shrubs, one tree, three inches of shredded hardwood mulch, 30 inches of a planting medium that consists of sand, peat, and native topsoil, and a gravel layer surrounding an 8-inch perforated underdrain pipe.

##### **MSD FUNDING LEVELS**

MSD funding is 5.4% of the total school construction cost.

Design: \$13,800

Construction: \$478,105

##### **PROJECT BENEFIT**

The project demonstrates the use of large vegetative roofs in a highly urbanized educational setting. The estimated annual volume of captured runoff is 610,000 gallons<sup>1</sup> with the cost per captured gallon of \$0.78.

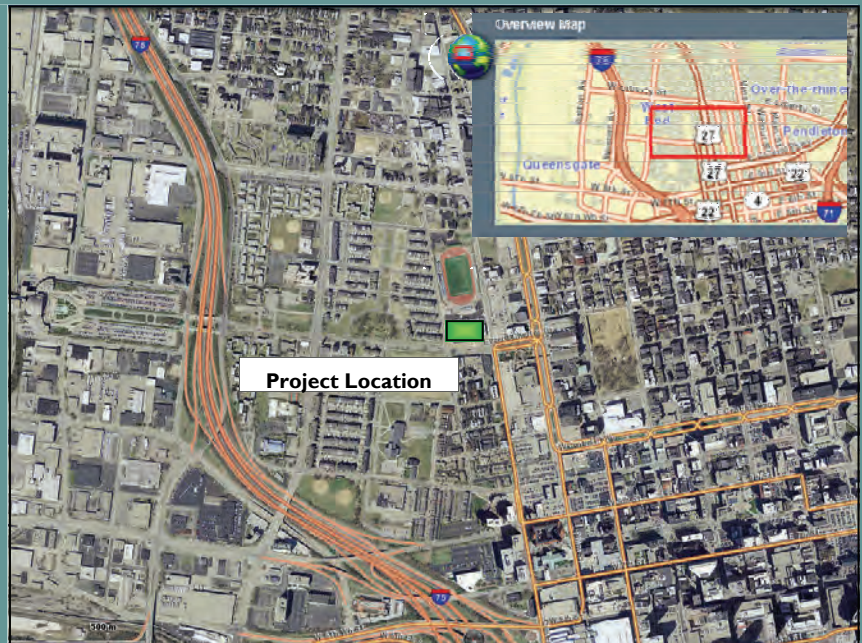

#### ***MONITORING***

The project is being monitored through a site inspection program where the facility is visited annually to assess performance of the installed green roof and to identify any operation and maintenance needs.



<sup>1</sup>The typical year used in this estimate assumes a total annual Rainfall of 41 inches.

**Extensive Vegetative Roof**

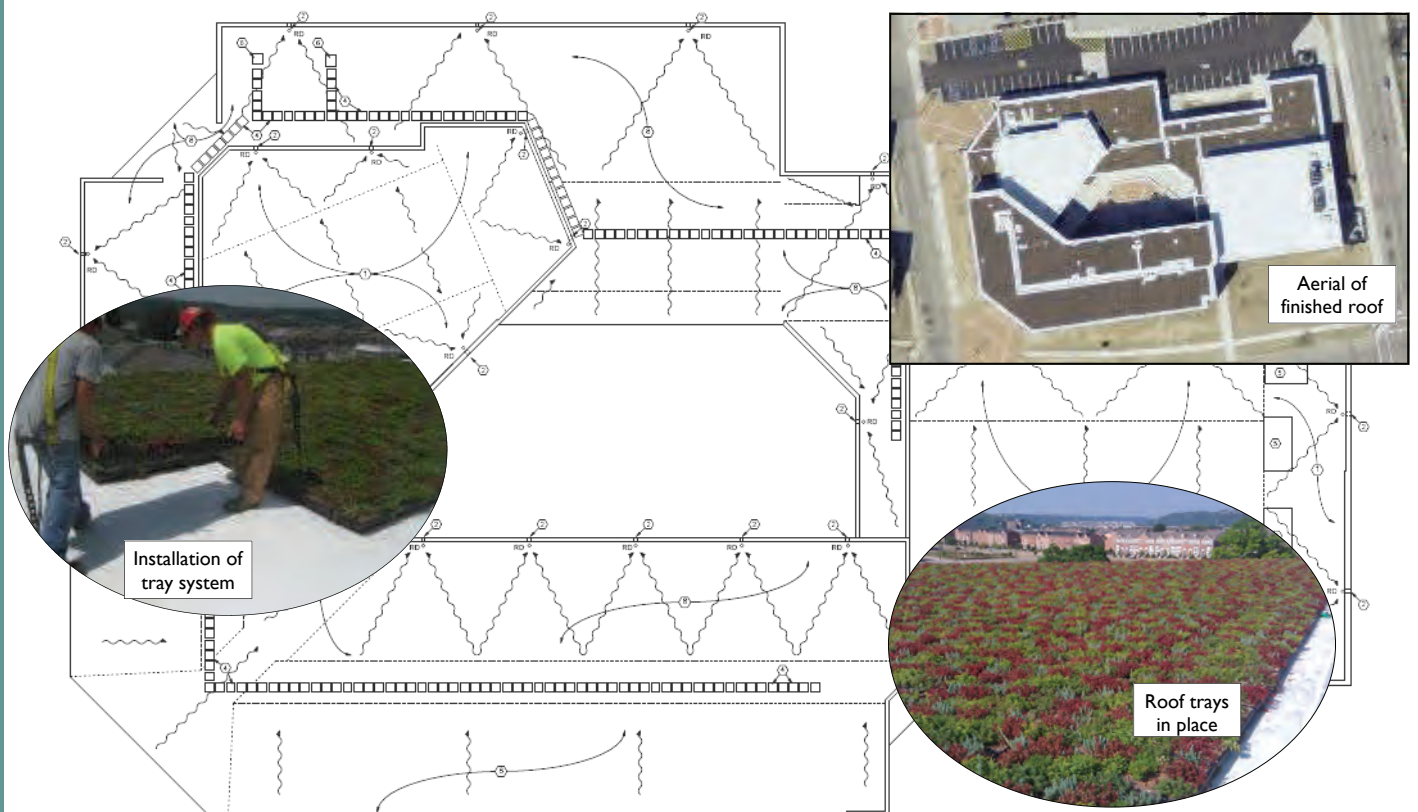

**Rain Garden**





## **ENABLED IMPACT PROJECT UPDATE**

### **PROJECT: TAFT IT HIGH SCHOOL**

**PROJECT PARTNER: CINCINNATI PUBLIC SCHOOLS**



***Lesson Learned: Vegetative roofs may be more cost effective on existing structures with adequate structural stability.***

Structural analyses are required to determine how the loading of a green roof can impact an existing or proposed structure. In this circumstance, additional steel was needed to support the loading of the green roof, which adds to the cost of the feature. Vegetative roofs may ultimately be more feasible on existing structures with adequate structural stability to support a green roof.



Extensive vegetative roof at Taft IT High School.

## ENABLED IMPACT PROJECT FACT SHEET

### PROJECT: EVANSTON AQUATIC CENTER

PROJECT PARTNER: CINCINNATI RECREATION COMMISSION

PROJECT STATUS: Complete

CSO BASIN(S): No. 487

WATERSHED: South Branch Mill Creek



#### PROJECT LOCATION

Located in the Evanston neighborhood of Cincinnati, Ohio, the site is on Woodburn Road and bound by Hewitt Avenue on the north and Fairfax Road on the south.

#### SITE DESCRIPTION

**Project size/setting:** The 4.05 acre site includes a swimming pool, parking lot, and recreation areas located in primarily residential area.

**Drainage area to green infrastructure:** 121,900 square feet

#### GREEN INFRASTRUCTURE FEATURES

Green stormwater management features include two bioretention basins and a series of porous concrete parking stalls whose locations are shown on the concept plan below.

##### Bioretention Basins

Two bioretention basins on the site collect, store, and infiltrate stormwater runoff. The larger of the two basins is 8,000-square feet and the smaller basin is 2,300-square feet. However, the amended soil area is only 4,160-square feet for the larger basin, and 1,260-square feet for the smaller basin. The stormwater from the new building's roof and the majority of the project site drains to these two basins. The basins are planted with native plants to evapotranspire, and cleanse the runoff.

##### Porous Concrete

A total of approximately 3,000 square feet of porous concrete parking stalls infiltrate stormwater runoff from adjacent traditional asphalt surfaces.

##### MSD FUNDING

Design: \$15,000

Construction: \$142,516

Education & Signage: \$6,000

MSD funding comprises 12% of the total Evanston Aquatic Center construction cost.

##### PROJECT BENEFIT

The project goal is to demonstrate small scale green controls in an urban-recreational setting. The controls are visible to everyone utilizing the facility. The estimated annual volume of captured runoff is 1,728,660 gallons<sup>1</sup> with a construction cost per captured gallon of approximately \$0.08.

##### MONITORING

Seasonal site inspections will be conducted quarterly to assess long-term viability of the green controls and to identify potential operation and

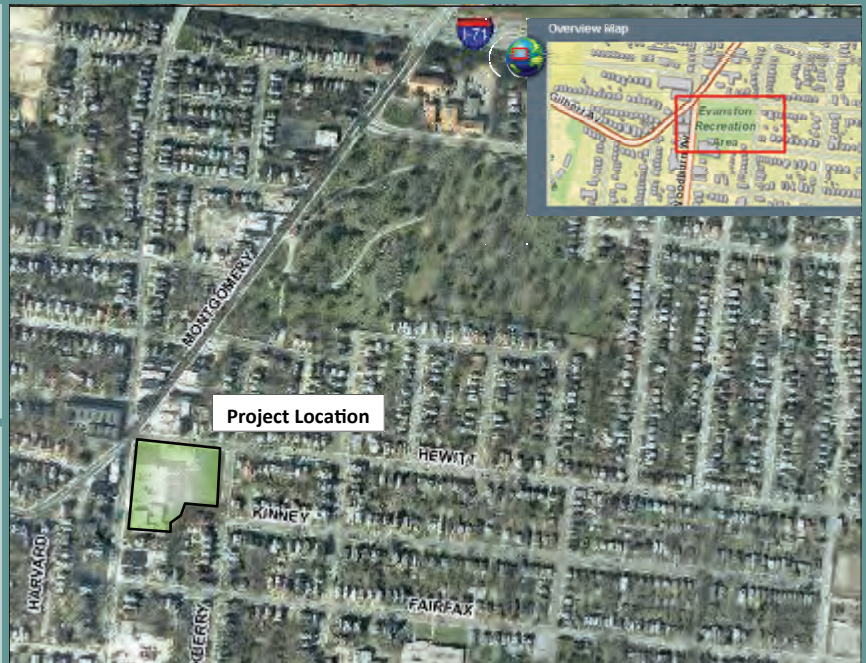

maintenance issues. Site visits are conducted after high intensity wet weather events to assess performance of the controls and, where appropriate, overflow structures.



<sup>1</sup>The typical year used in this estimate assumes total annual rainfall of 41 inches.

**ENABLED IMPACT PROJECT FACT SHEET**  
**PROJECT: EVANSTON AQUATIC CENTER**  
**PROJECT PARTNER: CINCINNATI RECREATION COMMISSION**



**Evanston Aquatic Center Demonstration Project Plan and Installed Green Infrastructure**

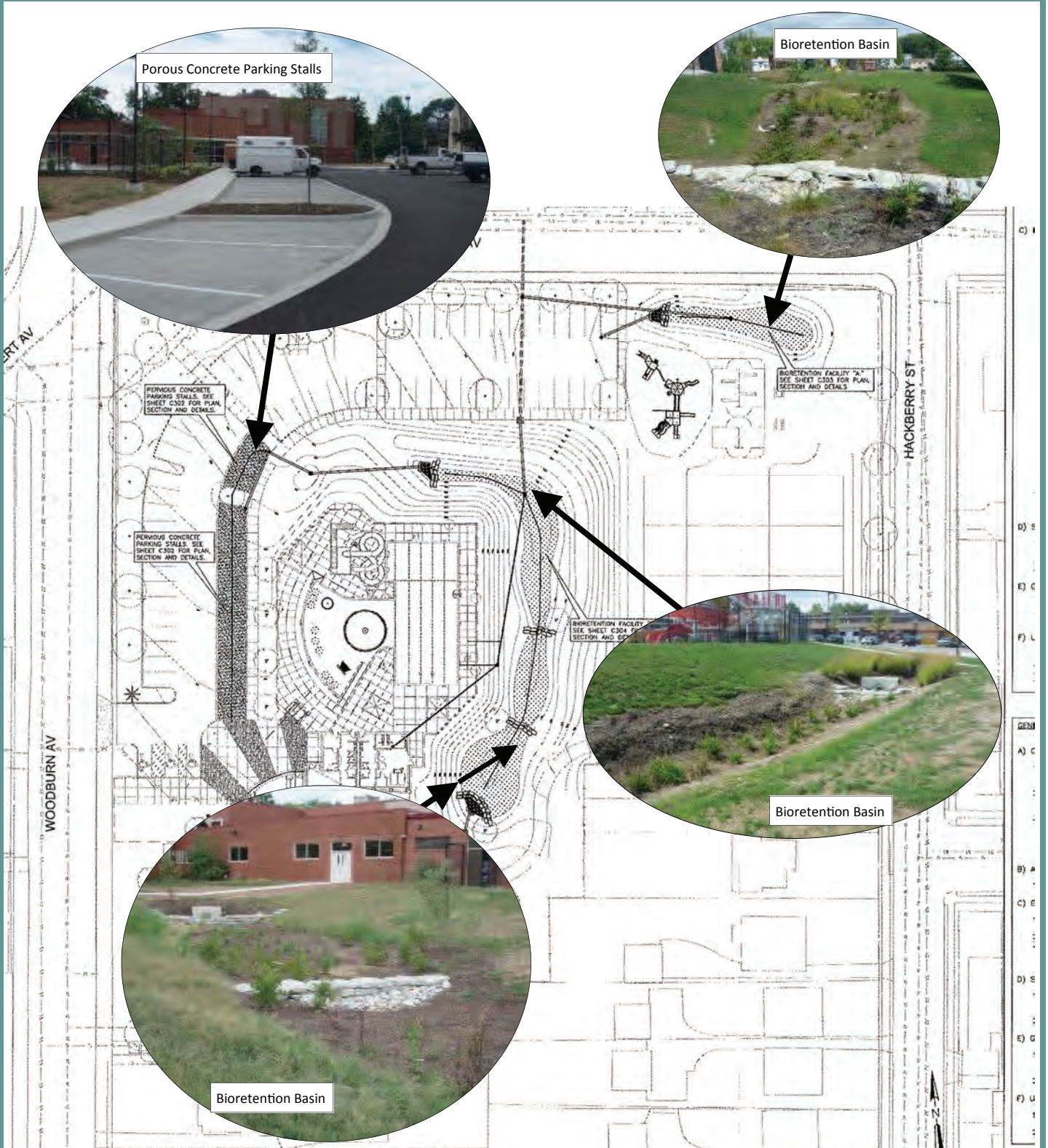

For more information about Project Groundwork, the Enabled Impact Program, or this project please email  
Lynn Lodor, Environmental Programs Manager at: [MaryLynn.Lodor@cincinnati-oh.gov](mailto:MaryLynn.Lodor@cincinnati-oh.gov) .

Mary-

***Lesson Learned: Design green features to prevent concentrated flow paths causing erosion.***

Concentrated flow paths can cause erosive flows and problems with erosion within bioinfiltration green features. Design considerations, such as energy dissipation at the outlet into the feature or minor tweaks to the grading, should have been included in the detailed design of the feature. As this was an early project in the program, energy dissipation was introduced into the design of remaining projects.



Erosion in the bioinfiltration basin.

***Lesson Learned: Construction contractors do not always understand the design features for green infrastructure. This can lead to improperly installed controls.***

The construction contractor installed a sloped bed rather than the designed stepped bed as it was the easier approach to installing the bed surface. Construction oversight personnel noticed this and brought it to the attention of the design team. After a review of the design, it was decided in this instance that the change in design should have little impact on performance and the sloped bed was allowed to remain. All contractors and subcontractors need to understand that these types of features do not necessarily follow standard construction practices.

## ENABLED IMPACT PROJECT UPDATE

### PROJECT: Former Habig's Parking Lot ESP

PROJECT PARTNER: Westwood Community Redevelopment Corp. (WestCURC)

PROJECT STATUS: Completed

CSO BASIN(S): 005

WATERSHED: Lick Run



#### PROJECT LOCATION

The project is located at 3009 Urwiler Avenue, on Cincinnati's east side, in the Westwood Community, at the southwest intersection of Urwiler Avenue and Harrison Avenue.

#### SITE DESCRIPTION

**Project size/setting:** The project area is approximately 3,700 square-feet in an urban setting. The project site is a former restaurant site, and is now an impervious asphalt parking lot.

#### Drainage area to green infrastructure:

The drainage area for all the green features on this site includes approximately 19,800 square feet of the surrounding parking lot.

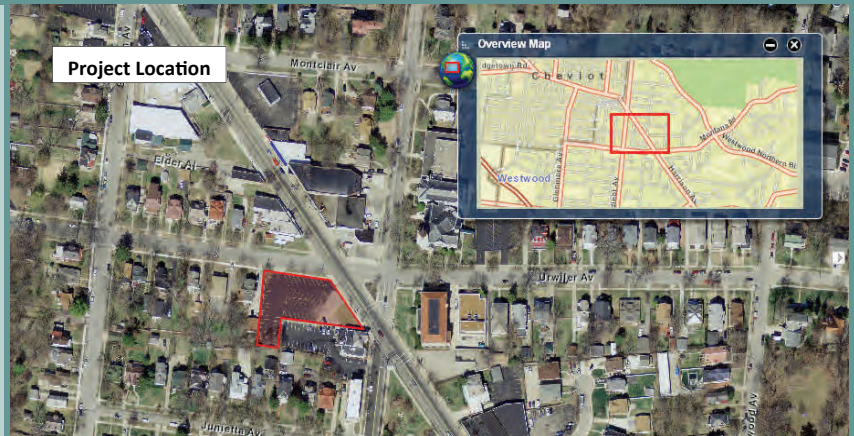

#### GREEN INFRASTRUCTURE FEATURES

The project contains approximately 2,100 square-feet of permeable pavers which accept runoff from approximately 40% of the site. Stormwater is infiltrated into the aggregate layer below the surface of the pavers, and then directed via perforated drain pipe through a sub-surface concrete wall into a 1,600 square-foot bioinfiltration facility. Upon saturation of the bioinfiltration facility, stormwater is directed via drain pipe, or an overflow structure during heavy wet weather events, to MSDGC's sewer system.

#### MSD FUNDING

Design: Design services were provided by the Human Nature / Strand team in conjunction with all other ESP's completed to date.

Construction: \$87,173<sup>1</sup>

Operation and Maintenance: O&M of the installed green stormwater features will be provided by the property owner, WestCURC.

#### PROJECT BENEFIT

The estimated total annual volume of runoff removed from the combined sewer system is 0.4M gallons<sup>2</sup>. Cost per gallon of captured runoff is estimated at \$0.28.

#### MONITORING

Seasonal site inspections will be conducted by Cincinnati Parks Department (via an in-place MOU) to assess long-term viability of the green controls and identify potential operation and maintenance issues.

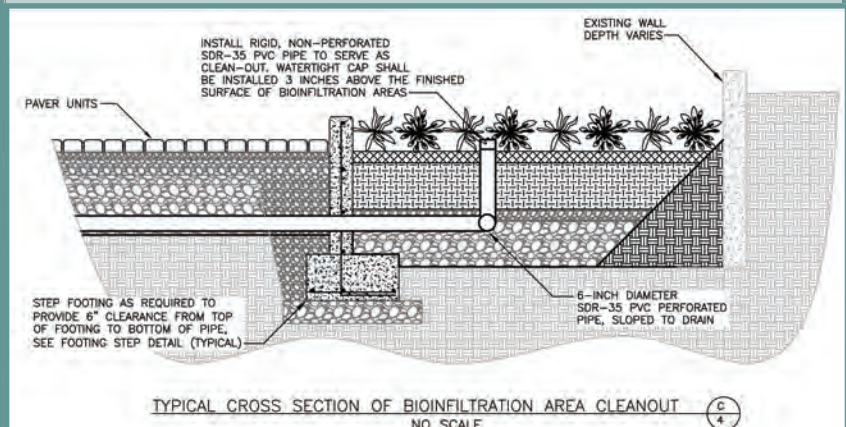

<sup>1</sup>Construction costs are approximate pending receipt of all invoices.

<sup>2</sup>The typical year used in this estimate assumes total annual rainfall of 41 inches.

## **ENABLED IMPACT PROJECT UPDATE**

**PROJECT: Former Habig's Parking Lot ESP**

**PROJECT PARTNER: Westwood Community Redevelopment Corp. (WestCURC)**



**Bioinfiltration Facility**



**Construction of Controls**



**Bioinfiltration Facility with Overflow Structure**



**Sequence of Construction**

The sub-grade for the permeable pavers was excavated and placed prior to construction of the bioretention facility foundation wall, and excavation of the facility, in order to preserve the infiltration integrity of the facility.

**Pervious Pavers**



**Installation of Engineered Soil**



**Permeable Paver Aggregate Installation**



For more information about Project Groundwork, the Enabled Impact Program, or this project please email  
Lynn Lodor, Environmental Programs Manager at: [MaryLynn.Lodor@cincinnati-oh.gov](mailto:MaryLynn.Lodor@cincinnati-oh.gov) .

Mary-

## **ENABLED IMPACT PROJECT UPDATE**

### **PROJECT: Harrison Avenue ESP**

**PROJECT PARTNER:** Cincinnati Department of Transportation & Engineering

**PROJECT STATUS:** Fall 2013 Construction start

**CSO BASIN(S):** 5

**WATERSHED:** Lick Run



#### ***PROJECT LOCATION***

The project is located in the Cincinnati neighborhood of South Fairmount. The project site is bound by Tremont Street to the east and Harrison Avenue to the south.

#### ***SITE DESCRIPTION***

**Project size/setting:** The project area is approximately 450 square-feet in a residential area.

#### **Drainage area to green infrastructure:**

The drainage area for the green feature on this site includes approximately 0.78 acres of wooded and developed residential area.

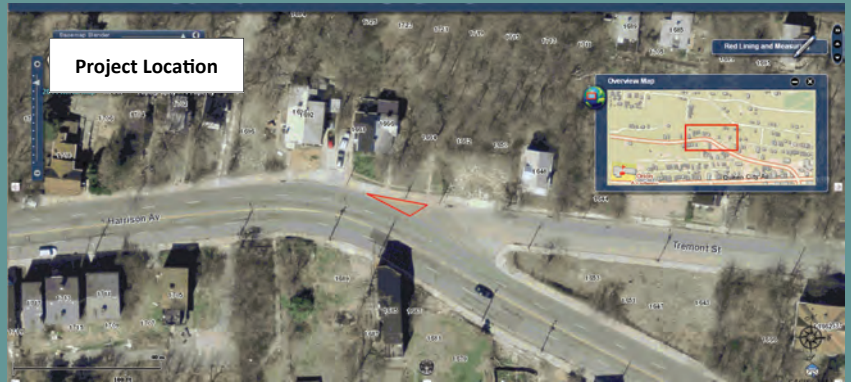

#### ***GREEN INFRASTRUCTURE FEATURES***

MSD proposes to construct a street curb bump out bioinfiltration facility at the intersection of Harrison Avenue and Tremont Street. The project will manage stormwater through green infrastructure and serve as a community asset to the northern part of South Fairmount and the surrounding areas. This project was designed in conjunction with the Harrison Avenue Phase A project (currently in construction phase).

#### ***MSD FUNDING***

**Design:** Design services were provided by the Human Nature / Strand team in conjunction with all other ESPs completed to date.

**Construction Estimate:** \$13,817

**Operation and Maintenance:** O&M of the installed green stormwater features will be provided by Cincinnati Park Board.

#### ***PROJECT BENEFIT***

Conceptual designs estimate the total potential annual volume of runoff removed from the combined sewer system to be 0.24M gallons<sup>1</sup>.

#### ***MONITORING***

Seasonal site inspections will be conducted by Cincinnati Parks Department (via an in-place MOU) to assess long-term viability of the green controls and identify potential operation and maintenance issues.



#### ***PROJECT STATUS UPDATE***

The Harrison Avenue ESP is contingent upon the construction of the Harrison Avenue Phase A project which is currently underway. Based on the latest schedule provided by the General Contractor, the concrete framework for the curb bump out will be cast between July and September 2013. MSD will coordinate to bid and construct the ESP within 30 days after the concrete is cast (per the engineer's recommendation.)

<sup>1</sup>The typical year used in this estimate assumes total annual rainfall of 41 inches.

## ENABLED IMPACT PROJECT UPDATE

### PROJECT: Immanuel Christ Church ESP

PROJECT PARTNER: Immanuel Christ Church

PROJECT STATUS: Complete

CSO BASIN(S): 005

WATERSHED: Lick Run



#### PROJECT LOCATION

The project is located at 1520 Queen City Avenue, on Cincinnati's east side, in the South Fairmount Community.

#### SITE DESCRIPTION

**Project size/setting:** The project area is approximately 1,800 square-feet in an urban setting. The project site is a developed church with landscaping and a parking area.

#### Drainage area to green infrastructure:

The drainage area for all the green features on this site includes approximately 5,400-square-feet of roof area, and approximately 1,400-square-feet of landscaped surfaces.

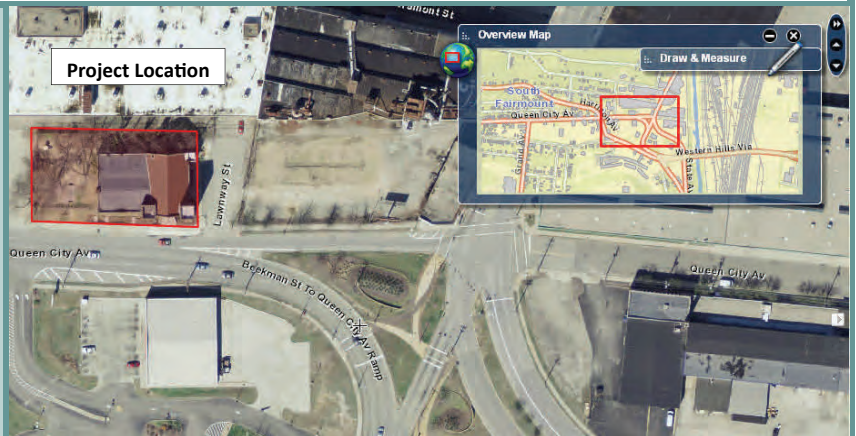

#### GREEN INFRASTRUCTURE FEATURES

The project contains approximately 800 square-feet of bioinfiltration area. Stormwater is redirected from the downspouts and landscaped areas adjacent to the building into the bioinfiltration area. Upon saturation of the bioinfiltration area, stormwater is directed via drain pipe, or an overflow structure during heavy wet weather events, to MSDGC's sewer system.

#### MSD FUNDING

Design: Design services were provided by the Human Nature / Strand team in conjunction with all other ESP's completed to date.

Construction: \$30,000

Operation and Maintenance: O&M of the installed green stormwater features will be provided by the property owner, Immanuel Christ Church.

#### PROJECT BENEFIT

The estimated total annual volume of runoff removed from the combined sewer system is 0.01M gallons<sup>1</sup>.

#### MONITORING

Seasonal site inspections will be conducted by Cincinnati Parks Department (via an in-place MOU) to assess long-term viability of the green controls and identify potential operation and maintenance issues.



<sup>1</sup>The typical year used in this estimate assumes total annual rainfall of 41 inches.



## **ENABLED IMPACT PROJECT FACT SHEET**

### **PROJECT: NORTH FAIRMOUNT SPRAYGROUND**

**PROJECT PARTNER: CINCINNATI RECREATION COMMISSION**

**PROJECT STATUS: Complete**

**CSO BASIN(S): NO. 10**

**WATERSHED: DENHAM**



**PROJECT GROUNDWORK**  
your pipeline to clean water

#### ***PROJECT LOCATION***

Located in Cincinnati, Ohio's North Fairmount neighborhood, the site is on Denham Street, and is bound by Carlil Street on the south and Linden Street on the east.

#### ***SITE DESCRIPTION***

**Project site/setting:** 1.6-acre playground owned by the Cincinnati Recreation Commission, located in an urban residential area .

**Drainage area to green infrastructure:** 13,070 square feet

#### ***GREEN INFRASTRUCTURE FEATURES***

Green stormwater management features include pervious concrete sidewalks and a pervious concrete amphitheater. The pervious concrete features were constructed in 2011. The locations of these green features are shown on the adjacent site plan.

#### **Pervious Pavement—Concrete**

A total of 2,670 square feet of pervious concrete sidewalks were installed to collect and filter stormwater runoff from the site.

#### ***MSD FUNDING***

Construction of Pervious Pavement: \$29,400

#### ***PROJECT BENEFIT***

The estimated total annual volume of runoff removed from the combined sewer system is approximately 100,000 gallons. The estimated construction cost per MSD funded gallon captured for the project is \$0.29.

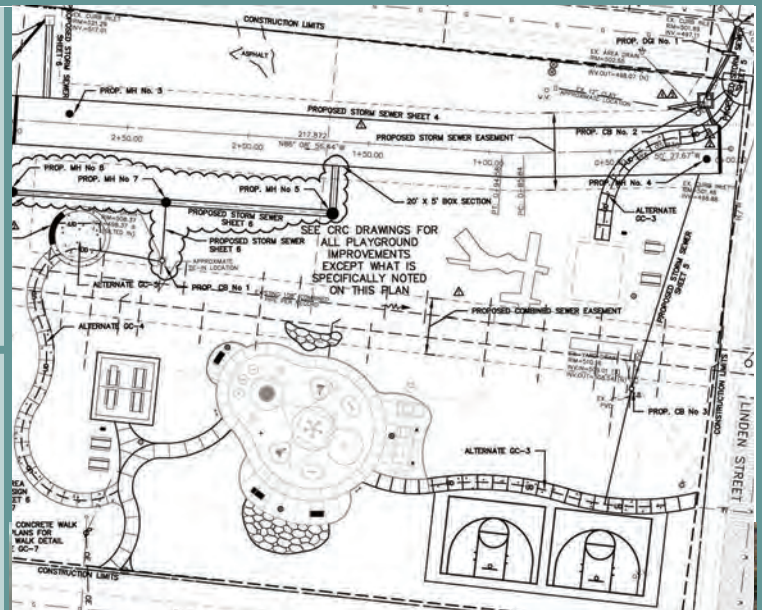

## ENABLED IMPACT PROJECT FACT SHEET

### PROJECT: OAKLEY SQUARE

PROJECT PARTNER: CINCINNATI DEPARTMENT OF TRANSPORTATION AND ENGINEERING

PROJECT STATUS: Complete

CSO BASIN(S): NO. 136

WATERSHED: Duck Creek



#### PROJECT LOCATION

Located in Cincinnati, Ohio's Oakley neighborhood, the site is on Madison Road and bound by Markbreit Avenue on the north and Eileen Drive on the south.

#### SITE DESCRIPTION

**Project site/setting:** 2.61 acres in an urban commercial area including multiple storefronts and the roadway.

#### Drainage area to green infrastructure:

39,815 square feet

#### GREEN INFRASTRUCTURE FEATURES

Green stormwater management features include several bioinfiltration planters, pervious concrete, and a bioinfiltration basin that were all completed in 2010. The locations of these green features are shown on the adjacent site plan.

#### Bioinfiltration Planters

Eight urban stormwater planters, totaling 730 square feet of vegetative area, were strategically located along the sidewalk to capture stormwater runoff and allow for an adequate egress zone for on-street parking. The planters include curb cuts and a trench drain to capture street runoff. The planters have an underdrain system which ties back into the combined sewer system.

#### Pervious Pavement—Concrete

A total of 1,670 square feet of pervious concrete sidewalks were installed to collect and filter stormwater runoff from adjacent traditional concrete sidewalks.

#### Bioinfiltration Basin

The project also included a small, 132 square feet bioinfiltration basin located on the northeast side of the project.

#### MSD FUNDING

Construction: \$183,500

Monitoring Equipment/Weather Station: \$20,000

~~Education and Signage: \$22,564~~

MSD funded 9% of the total construction cost.

#### PROJECT BENEFIT



The estimated total annual volume of runoff removed from the combined sewer system is approximately 220,000 gallons. The estimated construction cost per MSD funded gallon captured for the project is \$0.83.

#### MONITORING

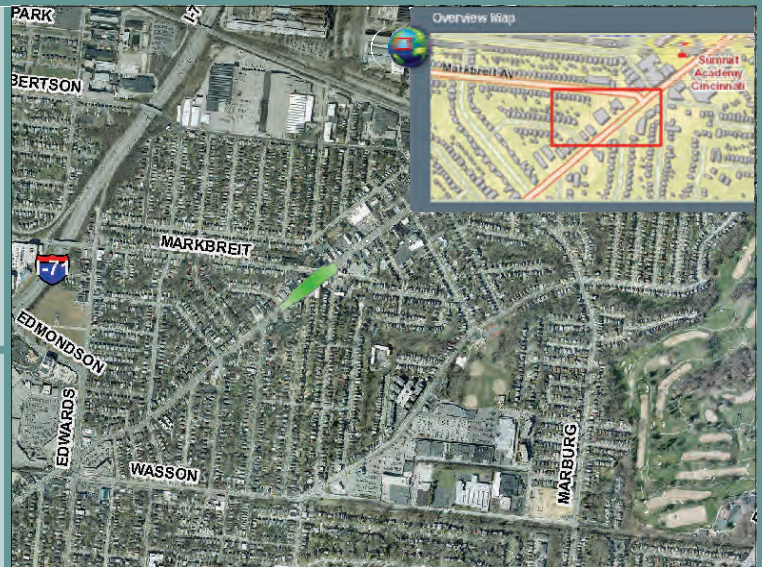
Seasonal site inspections will be conducted annually to assess long-term viability of the green controls and to identify potential operation and maintenance issues. Site visits will also be conducted after high intensity wet weather events to assess performance of the controls and, where appropriate, overflow structures.



#### Legend

-  Bioinfiltration Planter
-  Bioinfiltration Basin
-  Pervious Concrete

# ENABLED IMPACT PROJECT FACT SHEET

PROJECT: OAKLEY SQUARE

PROJECT PARTNER: CINCINNATI DEPARTMENT OF TRANSPORTATION ENGINEERING



## Oakley Square Green Street Design Plan and Photos

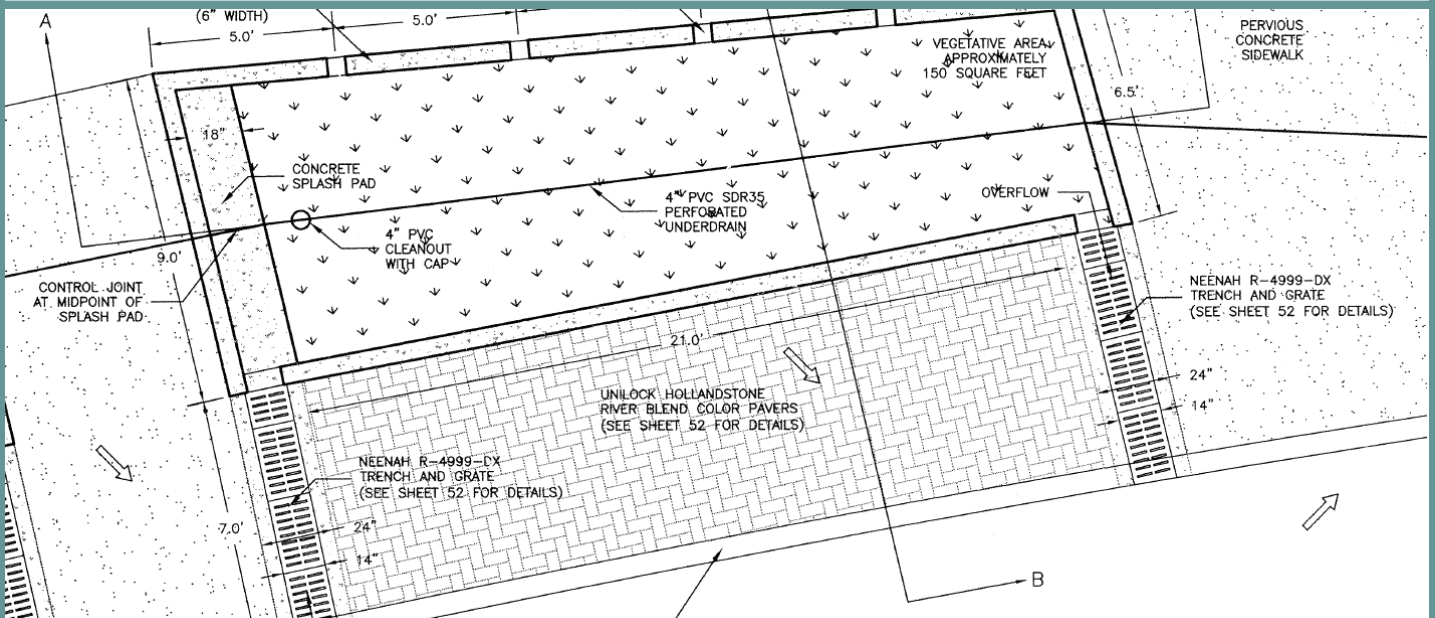

Bioinfiltration Basin



Porous Concrete



Bioinfiltration Street Planters



For more information about Project Groundwork, the Enabled Impact Program, or this project please email  
Lynn Lodor, Environmental Programs Manager at: [MaryLynn.Lodor@cincinnati-oh.gov](mailto:MaryLynn.Lodor@cincinnati-oh.gov) .

Mary-

## **ENABLED IMPACT PROJECT FACT SHEET**

### **PROJECT: OAKLEY SQUARE**

**PROJECT PARTNER: CINCINNATI DEPARTMENT OF TRANSPORTATION ENGINEERING**



#### ***Lesson Learned: Cost effective alternatives should be***

Bioretention planters in an urban setting can become costly, particularly within a sidewalk area that requires perimeter curbing or walls. The concrete required for this can add significant expense, and the construction required for the walls can become cumbersome for a smaller bioretention planter box. Other cost effective alternatives could be considered on similar projects to lower the overall project costs.



Bioretention planter box.

#### ***Lesson Learned: Maintenance plans and responsibilities should be determined before installing green features.***

Long-term maintenance of green features is important, and may become more difficult when multiple businesses are involved in a project. Although one entity plans to maintain these features, oversight may be needed to verify the features are being maintained properly. For example, a small area of porous concrete sidewalk shows signs of ponding water during heavy rain events, and should be cleaned.



Stormwater ponded on the porous concrete sidewalk.

#### ***Lesson Learned: Pedestrian safety should be considered.***

When designing green features, consider placement and visibility so pedestrians are aware of the feature. Although curbing and plants typically provide a clear distinction of a bioretention planter, other items to consider include small perimeter fencing, larger bushes, trees, or additional lighting. Installing some vegetation on both sides of the curbing to provide a buffer between the sidewalk and the depressed bioretention planter could be beneficial as well.



Stormwater planter located outside entrance/exit to theater.

## ENABLED IMPACT PROJECT FACT SHEET

### PROJECT: OSBORN AND COMER ALLEYS

PROJECT PARTNER: CINCINNATI DEPARTMENT OF TRANSPORTATION & ENGINEERING

PROJECT STATUS: Complete

CSO BASIN(S): No. 431A and No. 666

WATERSHED: South Branch Mill Creek



#### PROJECT LOCATION

These two separate projects are located in downtown Cincinnati, Ohio, directly north of Washington Park in Cincinnati's Over the Rhine neighborhood. The alleys are bound by West 14th on the south and West 15th Street on the north. Comer Alley is east of Osborn Alley.

#### SITE DESCRIPTION

**Project size/setting:** The total area of the two project sites is approximately 0.12 acres in an urban residential/commercial area.

**Drainage area to green infrastructure:** 5,320 square feet. Building downspouts and surrounding impervious area are routed to drain to the pervious paver systems in Osborn Alley. Surface runoff drains to the Comer Alley project.

#### GREEN INFRASTRUCTURE FEATURES

Unusually sandy/permeable soils underlie the entire site which provide the opportunity to use permeable pavers for onsite stormwater management. Local field tests indicate percolation rates ranging from 45 to 270 inches per hour in shallow soils. The alleys were constructed by salvaging, cleaning, and re-using historic clay bricks and granite pavers.

#### Permeable Pavers

The permeable pavement system designs include 5-inches of washed No. 57 aggregate below a 2- to 3-inch layer of Number 8 washed gravel as the setting bed, another 8 inches of an existing gravel/sand base maintained in its current condition, and reuse of the existing clay bricks and granite pavers. Both the Comer Alley and Osborn Alley permeable pavement systems cover a combined total of 5,320-square feet (2,660-square feet per alley).

#### MSD FUNDING

Design \$9,000

Construction: \$54,000

Education and Signage: \$4,500

MSD funded 73% of the total construction cost for these projects.

#### PROJECT BENEFITS

The project goal is to demonstrate the use of permeable paving in a highly visible urban setting. The estimated annual volume of captured runoff is 378,000 gallons<sup>1</sup> with a construction cost per captured gallon of \$0.14.



#### MONITORING

Seasonal site inspections will be conducted annually to assess long-term viability of the green controls and to identify potential operation and maintenance issues. Site visits will also be conducted after high intensity wet weather events to assess performance of the controls and, where appropriate, overflow structures.



<sup>1</sup>The typical year used in this estimate assumes total annual rainfall of 41 inches.

# ENABLED IMPACT PROJECT FACT SHEET

## PROJECT: OSBORN AND COMER ALLEYS

PROJECT PARTNER: CINCINNATI DEPARTMENT OF TRANSPORTATION & ENGINEERING



### Osborn Alley Paver Design Schematic

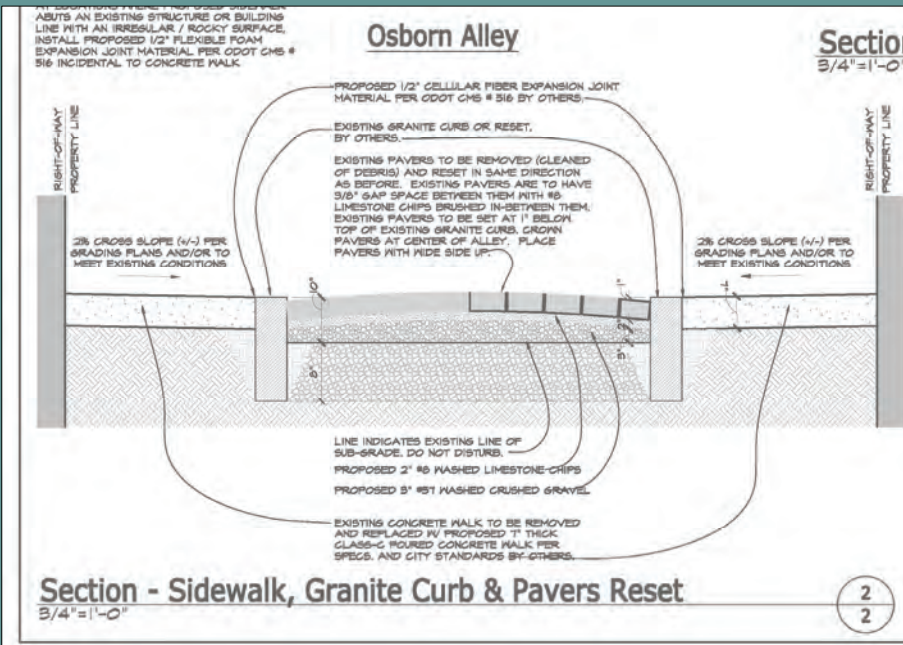

### Pervious Paver Alley Construction



Comer Alley Construction



Comer Alley Construction

### Comer Alley Paver Design Schematic

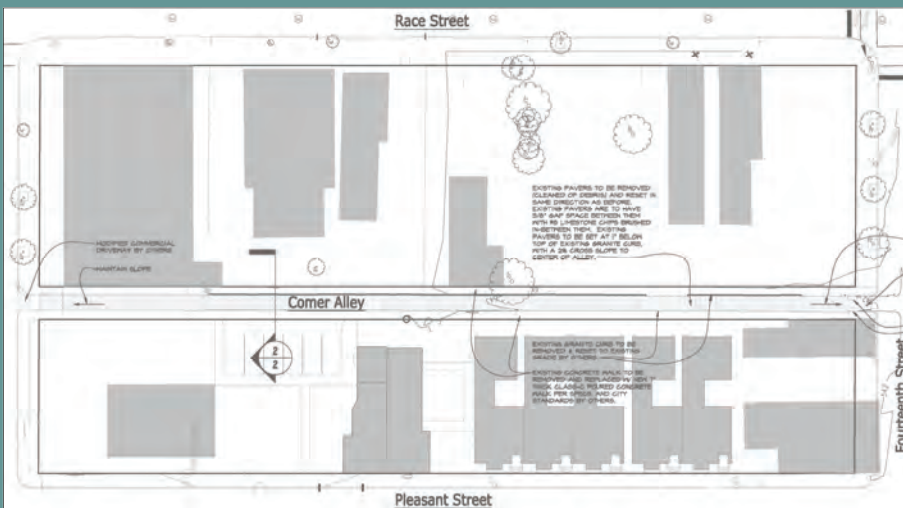

Comer Alley Permeable Pavers



Osborn Alley Construction



Osborn Alley Construction

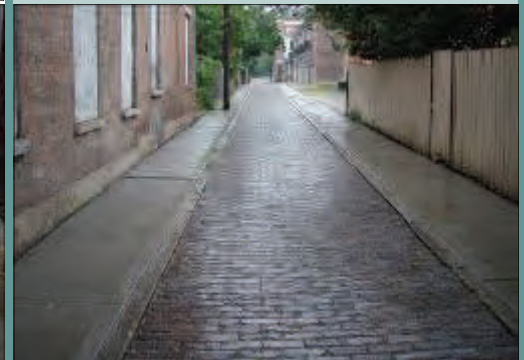

Comer Alley Construction Complete

For more information about Project Groundwork, the Enabled Impact Program, or this project please email MaryLynn Lodor, Environmental Programs Manager at: [MaryLynn.Lodor@cincinnati-oh.gov](mailto:MaryLynn.Lodor@cincinnati-oh.gov).

## **ENABLED IMPACT PROJECT FACT SHEET**

### **PROJECT: OSBORN AND COMER ALLEYS**

**PROJECT PARTNER: CINCINNATI DEPARTMENT OF TRANSPORTATION & ENGINEERING**



#### ***Lesson Learned: Traditional pavers can be reused as permeable pavers.***

Provided the design includes a gravel sub base, the pavers are washed appropriately and proper spacing is applied to allow for infiltration, existing traditional pavers can be reused as permeable pavers.



Existing pavers prepared to be reused as a porous pavement system.



Newly installed porous paver alley.

## ENABLED IMPACT PROJECT UPDATE

### PROJECT: Roselawn Park ESP

PROJECT PARTNER: Cincinnati Parks Department

PROJECT STATUS: Design Phase complete: Construction to start December 2013

CSO BASIN(S): 181

WATERSHED: Bloody Run



#### PROJECT LOCATION

The project is located at 2042 Seymour Avenue, on Cincinnati's north side, in the Roselawn Community.

#### SITE DESCRIPTION

**Project size/setting:** The project area is approximately 37,000 square-feet in a mixed-residential area. The project site is comprised of a parking lot, open lawn park space, and a vegetated slope.

#### Drainage area to green infrastructure:

The drainage area for all the green features on this site includes approximately 10.3 acres of surrounding parking lot and grassy park areas.



#### GREEN INFRASTRUCTURE FEATURES

The project consists of three bioinfiltration areas totaling approximately 8,500 square-feet which will accept all stormwater drainage from the 15.4-acre drainage area. The bioinfiltration areas work in series before conveying excess flows from the BMP's to MSDGC's sewer system. The project also includes approximately 11,000 square-feet of reforestation on a currently vegetated slope separating two of the three bioinfiltration areas.

#### MSD FUNDING

Design: Design services were provided by the Human Nature / Strand team in conjunction with all other ESP's completed to date.

Construction: \$465,515<sup>1</sup>

Operation and Maintenance: O&M of the installed green stormwater features will be provided by Cincinnati Park Board.

#### PROJECT BENEFIT

Conceptual designs estimate the total potential annual volume of runoff removed from the combined sewer system to be 0.526M gallons<sup>2</sup>.

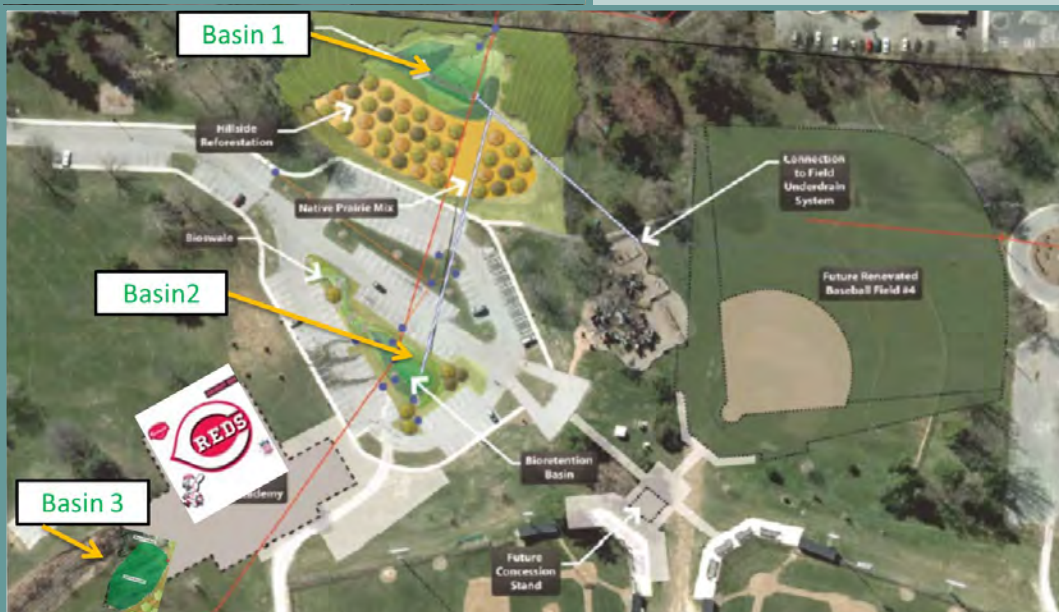

#### MONITORING

Seasonal site inspections will be conducted by Cincinnati Parks Department (via an in-place MOU) to assess long-term viability of the green controls and identify potential operation and maintenance issues.

<sup>1</sup>Construction costs are approximate pending receipt of all invoices.

<sup>2</sup>The typical year used in this estimate assumes total annual rainfall of 41 inches.



## ENABLED IMPACT PROJECT UPDATE

### PROJECT: San Antonio Church ESP

PROJECT PARTNER: Archbishop of Cincinnati

PROJECT STATUS: Complete

CSO BASIN(S): 198

WATERSHED: Lick Run



#### PROJECT LOCATION

The project is located at 1948 Queen City Avenue, on Cincinnati's east side, in the South Fairmount Community, at the northwest intersection of White Street and Queen City Avenue.

#### SITE DESCRIPTION

**Project size/setting:** The project area is approximately 6,300 square-feet in an urban setting. The project site is an impervious asphalt parking lot, and was formerly the site of residential structures.

#### Drainage area to green infrastructure:

The drainage area for all the green features on this site includes approximately 40,000 square feet of the surrounding parking lot and developed site.

#### GREEN INFRASTRUCTURE FEATURES

The project consists of approximately 4,100 square-feet of permeable pavers which accept runoff from approximately 85% of the site. Stormwater is infiltrated into the aggregate layer below the surface of the pavers, and then directed via perforated drain pipe into one of four 400 square-foot bioinfiltration facilities, which accept direct flow from the remaining approximately 15% of the site runoff. Upon saturation of the bioinfiltration facilities, stormwater is directed via drain pipe to MSDGC's sewer system.



#### MSD FUNDING

Design: Design services were provided by the Human Nature / Strand team in conjunction with all other ESP's completed to date.

Construction: \$192,808<sup>1</sup>

Operation and Maintenance: O&M of the installed green stormwater features will be provided by the property owner, San Antonio Church.

#### PROJECT BENEFIT

The estimated total annual volume of runoff removed from the combined sewer system is 0.47M gallons<sup>2</sup>. Cost per gallon of stormwater captured is \$0.41.

#### MONITORING

Seasonal site inspections will be conducted by Cincinnati Parks Department (via an in-place MOU) to assess long-term viability of the green controls and identify potential operation and maintenance issues.



<sup>1</sup>Construction costs are approximate pending receipt of all invoices.

<sup>2</sup>The typical year used in this estimate assumes total annual rainfall of 41 inches.

## ENABLED IMPACT PROJECT UPDATE

### PROJECT: St. Francis Court Apartments ESP

PROJECT PARTNER: St. Francis Community Urban Redevelopment Corporation

PROJECT STATUS: Phase I Complete

CSO BASIN(S): 005

WATERSHED: Lick Run



#### PROJECT LOCATION

The project is located at 1860 Queen City Avenue, on Cincinnati's east side, in the South Fairmount neighborhood.

#### SITE DESCRIPTION

**Project size/setting:** The project area is approximately 1.3-acres in an urban setting. The project site is paved parking for a former hospital turned apartment complex.

#### Drainage area to green infrastructure:

The drainage area for all the green features on this site includes approximately 2.3-acres of vegetated / forested hillside.

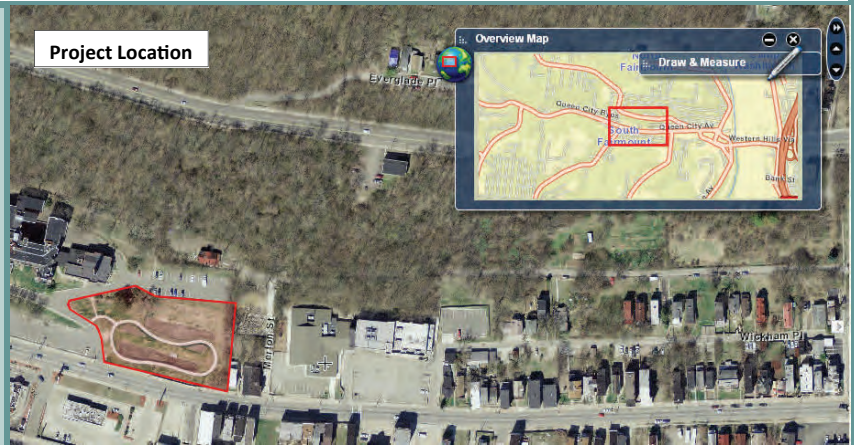

#### GREEN INFRASTRUCTURE FEATURES

The project contains approximately 8,750 square-feet of bioinfiltration areas. Stormwater is infiltrated into the soil layer below the mulched surface of the planted bioinfiltration areas. Upon saturation of the bioinfiltration facility, stormwater is directed via perforated drain pipe, or an overflow structure during heavy wet weather events, to MSDGC's sewer system.

#### MSD FUNDING

Design: Design services were provided by the Human Nature / Strand team in conjunction with all other ESP's completed to date.

Construction: \$236,000<sup>1</sup>

Operation and Maintenance: In the fall of 2012, MSD approached St. Francis with a conservation easement as a mechanism for ensuring proper maintenance of the basins. St. Francis agreed to pay MSD for maintenance; MSD is contracting the maintenance to Cincinnati Park Board.

#### PROJECT BENEFIT

The estimated total annual volume of runoff removed from the combined sewer system is 0.4M gallons<sup>1</sup>. Cost per gallon of captured runoff is estimated at \$0.59.

#### MONITORING

Seasonal site inspections will be conducted by Cincinnati Parks Department (via an in-place MOU) to assess long-term viability of the green controls and identify potential operation and maintenance issues.

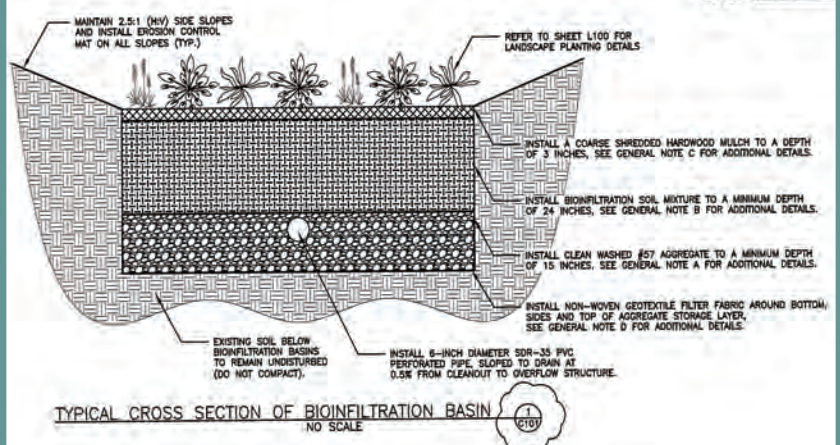
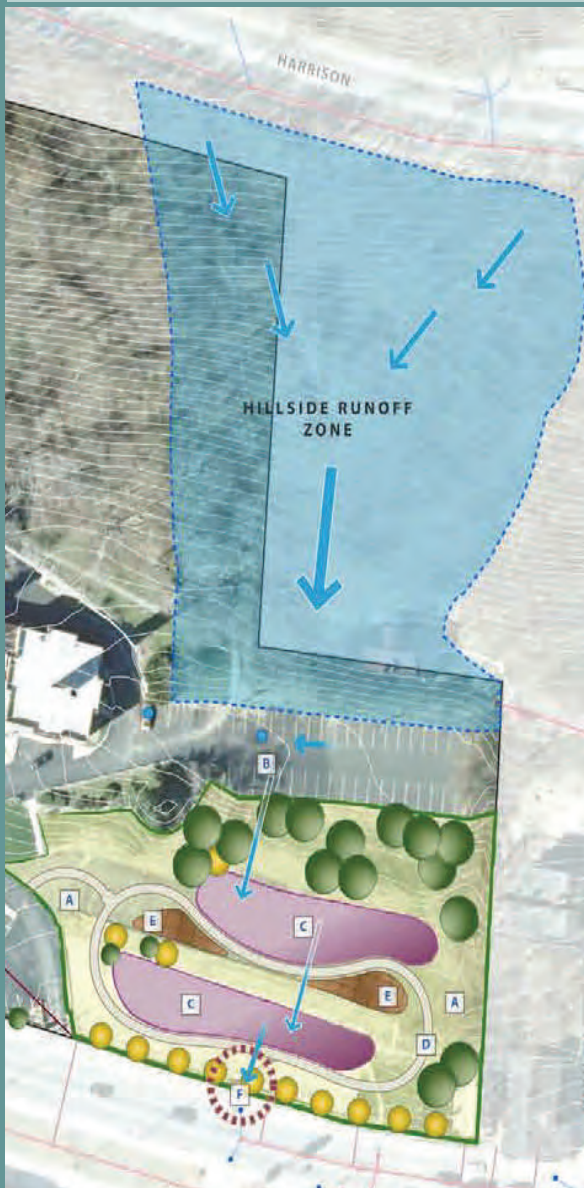

<sup>1</sup>The typical year used in this estimate assumes total annual rainfall of 41 inches.

## ENABLED IMPACT PROJECT UPDATE

### PROJECT: WASHINGTON PARK

PROJECT PARTNER: CINCINNATI PARK BOARD

PROJECT STATUS: Complete

CSO BASIN(S): No. 431 and No. 666

WATERSHED: South Branch Mill Creek



#### PROJECT LOCATION

Located on the north side of downtown Cincinnati, Ohio, the park site is bound by West 14th and 12th Streets on the north and south and Race and Elm Streets on the east and west.

#### SITE DESCRIPTION

**Project size/setting:** The project area is approximately 7.3 acres in an urban/urban-residential area. The project site was a former school and park.

#### Drainage area to green infrastructure:

The drainage area for all the green features on this site includes approximately 188,179 square feet of the surrounding park areas and adjacent roadways.



#### GREEN INFRASTRUCTURE FEATURES

Soil characteristics at the site provide a unique opportunity to use dry wells for onsite stormwater management in an urban setting. Construction was completed on these in 2011. Other stormwater management features include a street level, grassy vegetative roof installed on top of a new underground parking garage and smaller vegetative roofs on site buildings. The vegetated roof features were completed in 2012.

#### Drywells

Five drywells, each five feet in diameter, are designed to capture stormwater runoff from nearby streets and hard surfaces. The locations of these wells are shown on the site concept plan at left. Three wells are 35-ft deep and two wells are 40-ft deep. A design drawing and construction photographs of the wells are found on the other side of this fact sheet.

#### Vegetative Roofs

The 107,593 square foot grassy, extensive (shallow) vegetative roof will be installed at ground level on top of the new underground parking garage. The area was previously an impervious parking lot for the former school. An additional 3,933 square feet of extensive vegetative roof will be installed on five of the park buildings.

#### MSD FUNDING

Design: \$13,000

Construction: \$466,855<sup>1</sup>

Monitoring: \$20,000

Education and Signage: \$22,564

MSD funding comprises 1% of the total park renovation budget of \$47.5M.

#### PROJECT BENEFIT

The estimated total annual volume of runoff removed from the combined sewer system is 3,863,715 gallons<sup>2</sup>. The estimated construction cost per MSD funded gallon captured for the project is \$0.12. The actual cost per funded gallon for the dry wells is \$0.10.

#### MONITORING

Seasonal site inspections will be conducted to assess long-term viability of the green controls and identify potential operation and maintenance issues. A transducer was installed in each of the dry wells to measure the stormwater runoff leaving the system. MSD and CPB are working together to collect, download and analyze this data.

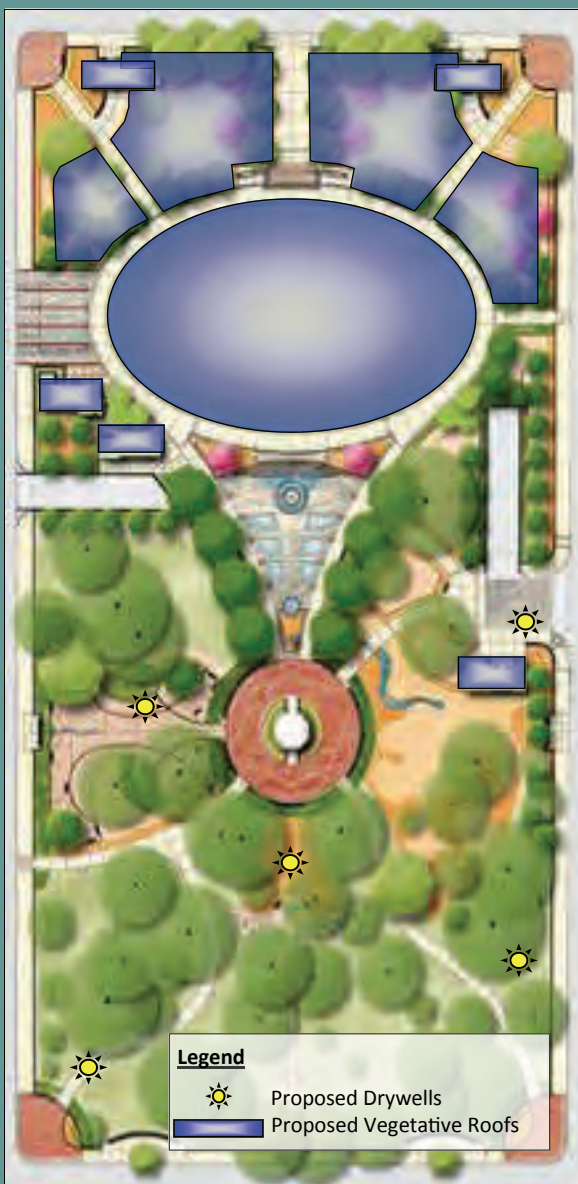

<sup>1</sup>Construction costs are approximate pending receipt of all invoices. <sup>2</sup>The typical year used in this estimate assumes total annual rainfall of 41 inches.

**ENABLED IMPACT PROJECT UPDATE**  
**PROJECT: WASHINGTON PARK**  
**PROJECT PARTNER: CINCINNATI PARK BOARD**



**Living Roof Design Schematic**

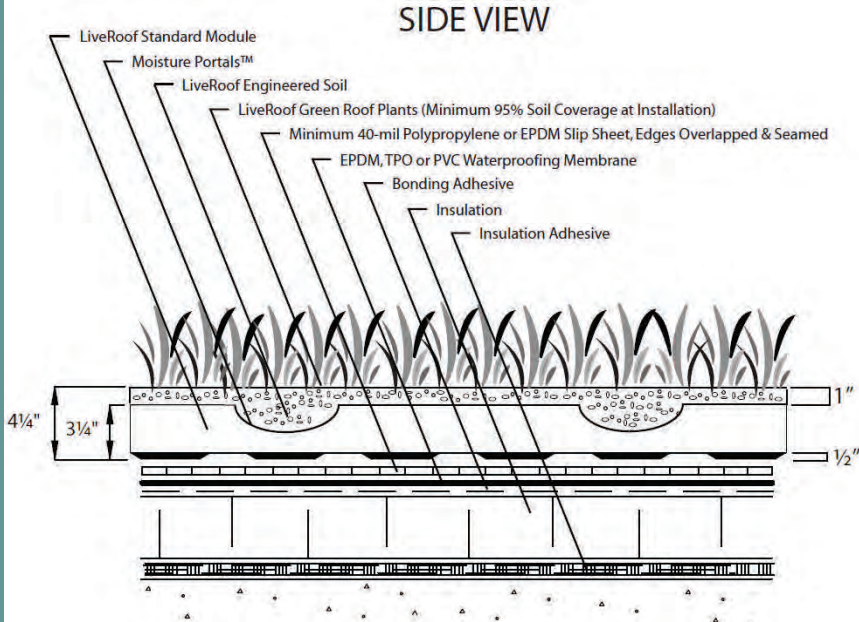

A vegetative roof consisting of 12 inches of topsoil and a layer of sod will cover the parking garage when complete. A network of underdrains were designed to protect this area from rain events greater than 2 inches of rainfall. As a result, volume reduction benefits will be achieved during the majority of storms during a typical year.

**Dry Well Construction**



**Drilling drywell with auger**



**Drywell barrels pre-installation**

**Dry Well Design Schematic**

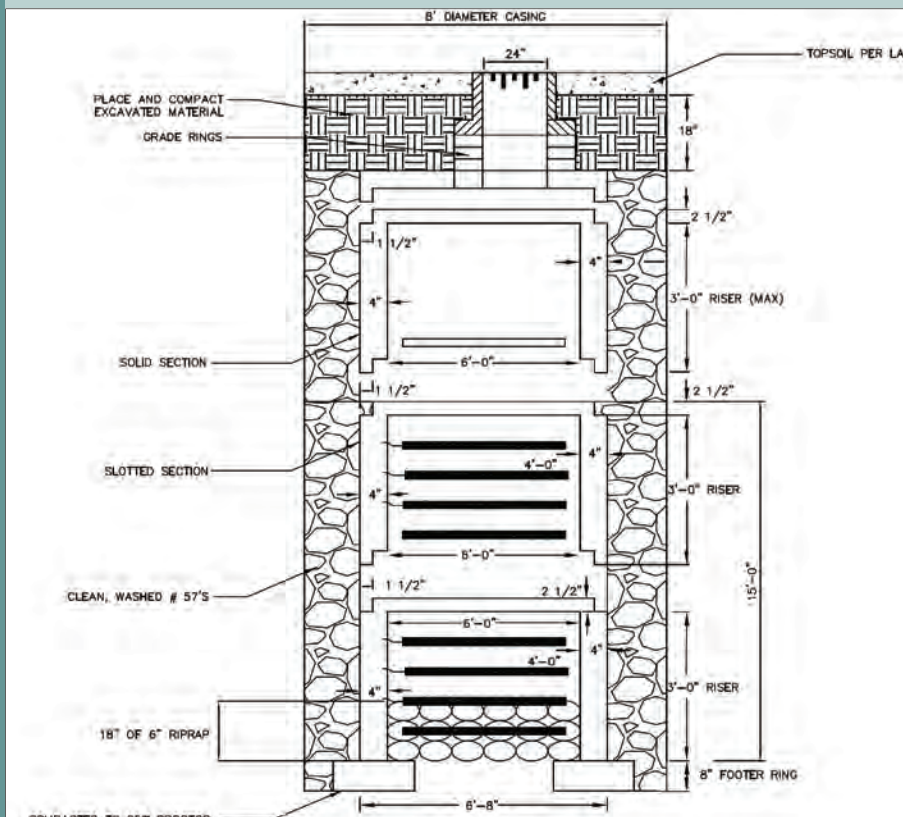

**Placing aggregate fill around barrel**



**Completed drywell without casting**

For more information about Project Groundwork, the Enabled Impact Program, or this project please email MaryLynn Lodor, Environmental Programs Manager at: [MaryLynn.Lodor@cincinnati-oh.gov](mailto:MaryLynn.Lodor@cincinnati-oh.gov).

## ENABLED IMPACT PROJECT UPDATE

### PROJECT: West Fork Creek Riparian/Floodplain Restoration Project

PROJECT PARTNER: Groundwork Cincinnati Mill Creek

PROJECT STATUS: Currently in final design phase; construction start expected Q2 2014

CSO BASIN(S): 128

WATERSHED: West Fork



#### PROJECT LOCATION

The project is located along West Fork Road just west of Colerain Avenue in the Northside neighborhood.

#### SITE DESCRIPTION

**Project size/setting:** The project area is approximately 25,000 square-feet in a residential area. Mount Airy Forest is to the north and the mill creek channel is to the south of the project location.

#### Drainage area to green infrastructure:

The drainage area for all the green features on this site includes approximately 2.10 acres.

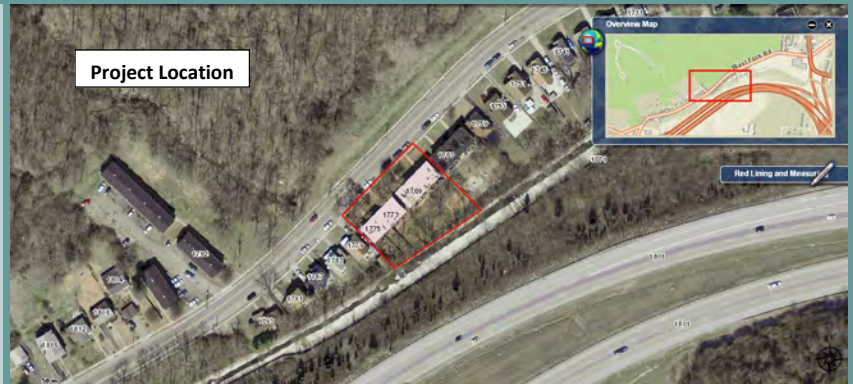

#### GREEN INFRASTRUCTURE FEATURES

This floodplain enhancement project site will be part of the long-term vision for renaturalization of the existing concrete-lined channel and enhance the channel corridor and floodplain. Specifically, this project will remove the flow entering the combined system, manage stormwater runoff diverted from West Fork Road through the stormwater features to the channel, incorporate native species of plants, provide dual purpose access trail and include educational signage for interpretive education and community outreach.

#### MSD FUNDING

Design Estimate: \$42,000

Construction Estimate: \$210,000

Grant Funds Awarded: \$219,420 (COF grant)

Operation and Maintenance: O&M of the installed green stormwater features will be provided by Cincinnati Park Board.

#### PROJECT BENEFIT

It is currently anticipated that in addition to providing a multi purpose community area, this project will help reduce the amount of runoff that enters the combined sewer by approximately 0.51M gallons<sup>1</sup>.

#### MONITORING

Currently, monitoring of the green controls is undefined. Most likely, seasonal site inspections will be conducted by Cincinnati Parks Department (via an in-place MOU) to assess long-term viability of the green controls and identify potential operation and maintenance issues.

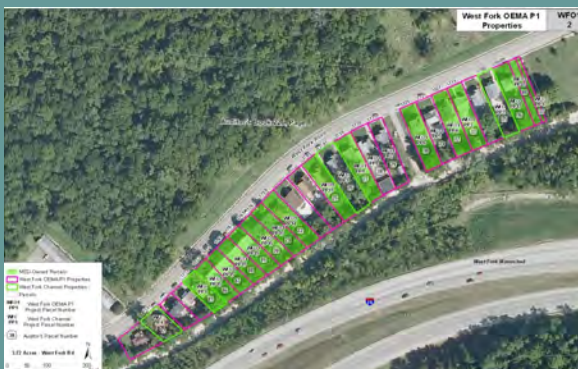

#### PROJECT STATUS UPDATE

The figure above details the properties affected. The green highlighted properties have been acquired by MSDGC to date.

Board of County Commissioners approved 2013 design and construction funds for this project. Currently in final design stage, this project is planning to start construction second quarter of 2014.



<sup>1</sup>The typical year used in this estimate assumes total annual rainfall of 41 inches.

## **ENABLED IMPACT PROJECT UPDATE**

### **PROJECT: WYOMING HIGH SCHOOL RAIN GARDEN**

**PROJECT PARTNER: WYOMING HIGH SCHOOL BOARD OF EDUCATION**

**PROJECT STATUS: Complete**

**CSO BASIN(S): No. 538 and No. 559**

**WATERSHED: West Branch Mill Creek**



#### ***PROJECT LOCATION***

Located in a suburb of Cincinnati, Ohio at the Wyoming High School. The rain garden site is in a detention basin on the south side of the northeast parking lot.

#### ***SITE DESCRIPTION***

**Project size/setting:** High school facility in suburban community. The total site is approximately 24 acres, with a rain garden footprint of 1,500 square feet.

**Drainage area to approved green infrastructure:** 4.375 acres encompassing roof, pavement, and grass areas.

#### ***GREEN INFRASTRUCTURE FEATURES***

Retrofitting the existing onsite detention basin allowed for the successful construction of the rain garden in 2011.

#### **Rain Garden**

The footprint of the 1,500 square foot rain garden sits at the lowest point of the pre-existing detention basin. Modifications to the outfall and overflow structure were made to allow for 10 inches of ponding in the proposed rain garden. There was no sand used in the soil mix for the feature. The underdrain ties back into the combined sewer system. The tributary area of the rain garden consists of two parking lots, an access road, the eastern rooftop area of the school, and adjacent lawn areas. The location of the rain garden utilized the site of an existing detention basin and outfall structure.

#### ***MSD FUNDING***

MSD funds comprised 96% of the cost of this small retrofit project.

Design: \$2,000

Construction: \$28,842

Education and Signage: \$1,286

Because the existing detention basin was utilized in the design, engineering fees for the project were minimized. Demolition and reconfiguration of the existing detention basin were included in the construction cost. Project partners are responsible for long-term maintenance.

#### ***PROJECT BENEFIT***

Stormwater calculations indicate the typical annual runoff volume from the tributary area is approximately 2,600,000 gallons with an estimated total annual runoff volume removed from the combined sewer system of 100,000<sup>1</sup> gallons. Construction cost per funded gallon for the project is \$0.07. Since the project is in a combined sewer area,

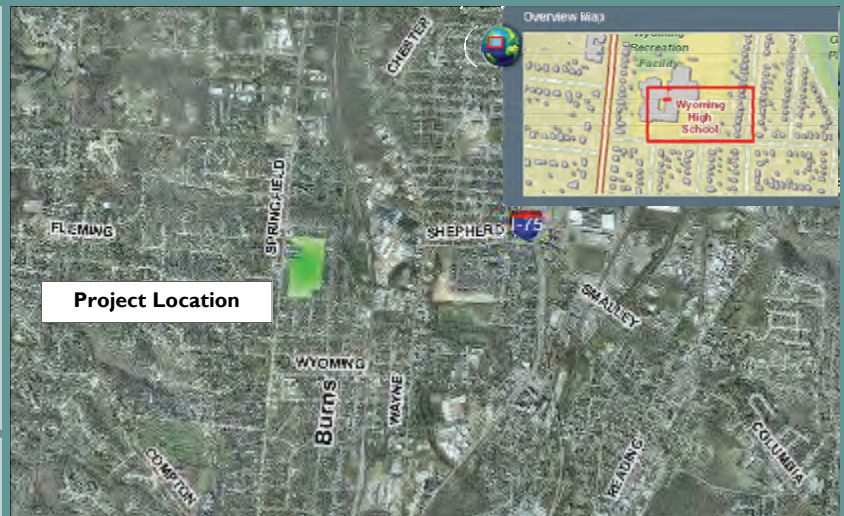

runoff volume reduction is one of the largest benefits. Education is another large benefit for the rain garden. The feature is located on a school site. Signage and the curriculum incorporate the benefits the feature brings to the combined sewer system for the entire community of Wyoming.

#### ***MONITORING***

Site inspections will be conducted annually to assess long-term viability of the green controls and to identify potential operation and maintenance issues. Site visits will also be conducted after high intensity wet weather events to assess performance of the controls and, where appropriate, overflow structures.

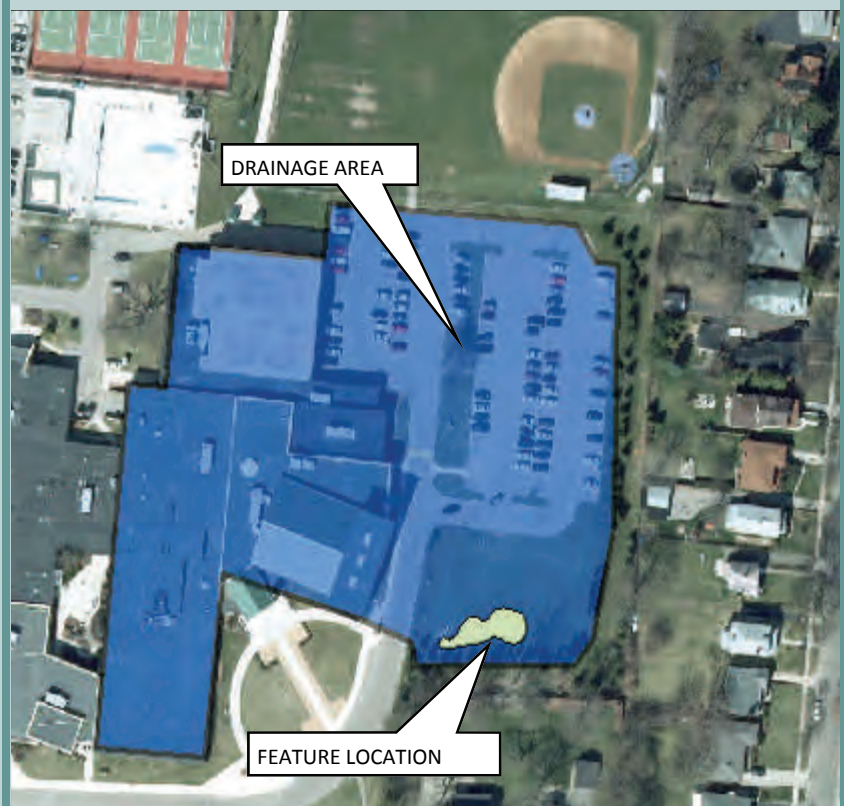

<sup>1</sup>The typical year used in this estimate assumes a total annual rainfall of 41 inches.

**ENABLED IMPACT PROJECT UPDATE**

**PROJECT: WYOMING HIGH SCHOOL RAIN GARDEN**

PROJECT PARTNER: WYOMING HIGH SCHOOL BOARD OF EDUCATION



**Rain Garden Photographs**

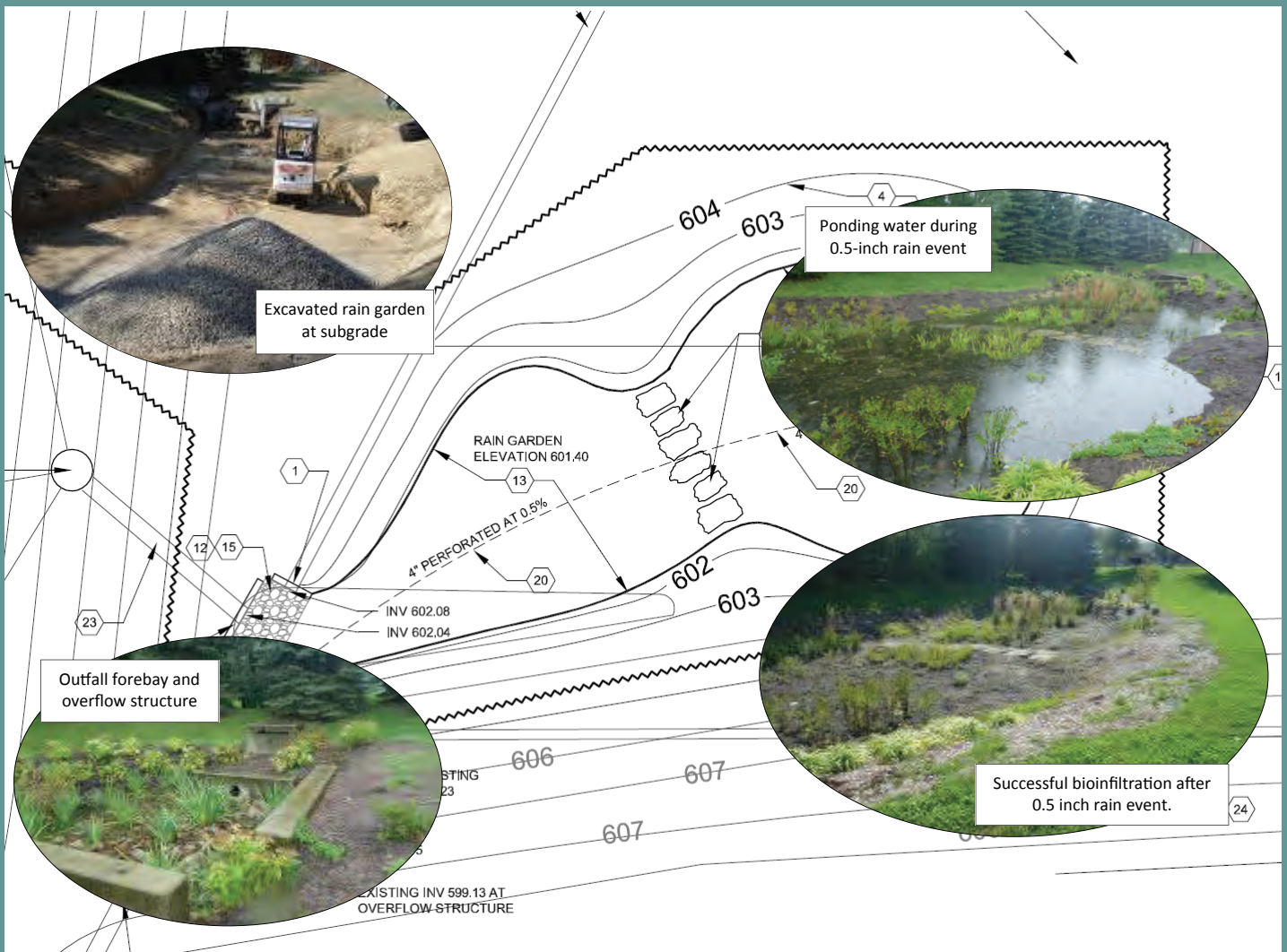

**Typical Cross Section**

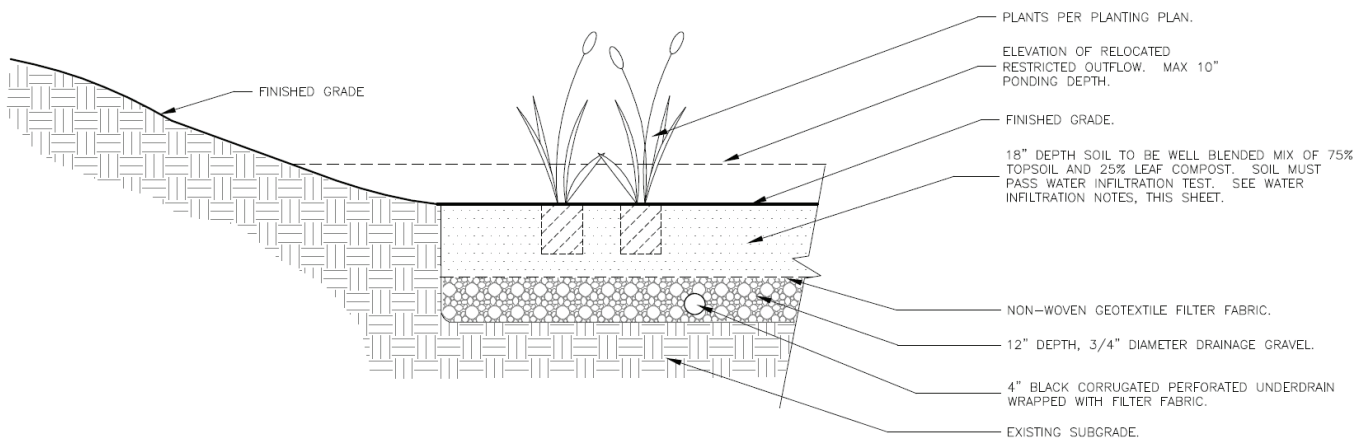

For more information about Project Groundwork, the Enabled Impact Program, or this project please email MaryLynn.Lodor, Environmental Programs Manager at: [MaryLynn.Lodor@cincinnati-oh.gov](mailto:MaryLynn.Lodor@cincinnati-oh.gov)

Mary-

## **ENABLED IMPACT PROJECT UPDATE**

### **PROJECT: WYOMING HIGH SCHOOL RAIN GARDEN**

**PROJECT PARTNER: WYOMING HIGH SCHOOL BOARD OF EDUCATION**



#### ***Lesson Learned: Bioinfiltration soil mix case studies provide useful information.***

The soil mix proposed for the Wyoming High School rain garden included a combination of 75 percent topsoil and 25% leaf compost, which is different than typical soil mixes that include high percentages of sand. Despite the different soil mix, initial percolation tests after placement of the soil indicated an infiltration rate of 0.5 inches per hour, which was the minimum design infiltration rate. Based on observations during and after rain events, the rain garden appears to be draining as designed. The different soil mix presents a good case study that should be monitored over a longer period of time.



Stormwater ponded in the bioinfiltration basin during a rain event.



The stormwater has infiltrated through the system 24 hours after the rain event.